



Parts Manual
E17/E20 Floor Scrubber
Traction Drive

Technical Specifications



Model E17/E20 Traction Drive

Model No. E17TD / E17TDCE / E17TDQP / E17TDQPCE
 E17TDQPG / E17TDQPGCE
 E20DTD / E20DTDCE / E20DTDQP / E20DTDQPCE
 E20DTDQPG / E20DTDQPGCE

	E17	E20
Current (Max)	38 amps	40 amps
Battery Capacity (Lead Acid)	140Ah @20 hr	140Ah @20 hr
Battery Capacity (Gel)	95Ah @20 hr	95Ah @20 hr
Sound Level	69 dBA	69 dBA
Cleaning path width	17 in (43 cm)	20 in (51 cm)
Squeegee width	30 in (76 cm)	34 in (86 cm)
Productivity (Traction Drive)	23,120 ft ² /hr (2,147 m ²)	27,200 ft ² /hr (2,527 m ²)
Working speed (Traction Drive)	3.1 mph (5 km per hr)	3.1 mph (5 km per hr)
Rated voltage	24 volts	24 volts
Vacuum flow	65 cfm (110 m ³ /hr)	65 cfm (110 m ³ /hr)
Vacuum waterlift	45 inches (112mbar)	45 inches (112mbar)
Vacuum power	.60 HP (450 W)	.60 HP (450 W)
Brush type	Disc	Disc
Brush motor(s) power	3/4 HP (560W)	3/4 HP (560W)
Number of brushes	1	1
Brush RPM	180 RPM	180 RPM
Aqua-Stop equipped	Coming Soon	Coming Soon
Solution capacity	12Gal (45 liters)	12 Gal (45 liters)
Recovery capacity	13 Gal (49 liters)	13 Gal (49 liters)
Working Grade	2%	2%
Weight with batteries	365 lbs (166 kg)	372 lbs (169 kg)
Weight without batteries	231 lbs (105 kg)	238 lbs (108 kg)
Dimensions (LxWxH)	44.4 x 18.8 x 42.3 (112.8 x 47.8 x 107.4 cm)	47.4 x 21.3 x 42.3 (120.4 x 54.1 107.4 cm)
Drive Motor Power	1/5 HP (150W)	1/5 HP (150W)

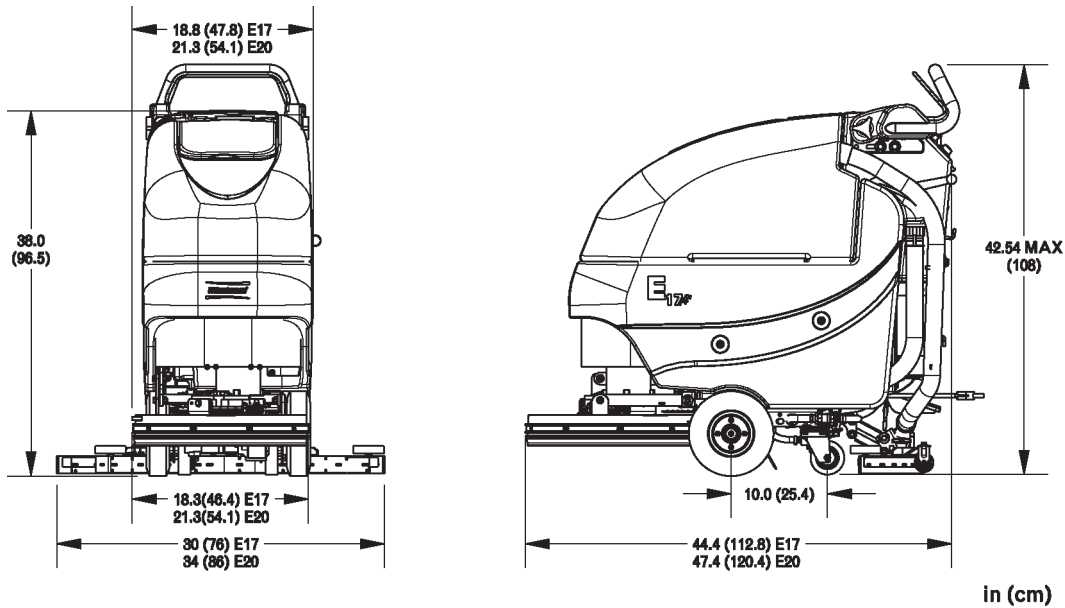

For Safety When Servicing or Maintaining Machine

- Stop on level surface.
- Disconnect the power to the machine by pulling the red Battery Connector located under the recovery tank near the batteries.
- Avoid moving parts. Do not wear loose jackets, shirts, or sleeves when working on machine.
- Avoid contact with battery acid. Battery acid can cause burns. When working on or around batteries, wear protective clothing and safety glasses. Remove metal jewelry. Do not lay tools or metal objects on top of batteries.
- Do not clean machine with a pressure washer.
- Authorized personnel must perform repairs and maintenance. Use Minuteman supplied replacement parts.

Table of Contents

Main Assembly	1
Main Assembly BOM	2
Traction Drive Base Assembly	3
Traction Drive Base Assembly BOM	4
E17/20 Base Assembly	5
Chassis Assembly	6
Chassis Assembly BOM	7
Solenoid Assembly	8
Solution Valve Assembly	8
Solution Tank Assembly	9
Lift Pedal Stop Assembly	10
Recovery Tank Assembly	11
Recovery Tank Assembly BOM	12
Handle Assembly	13
Battery Tray Assembly	14
Electrical Box Assembly	15
Electrical Box Assembly BOM	16
Electrical Box Cover Assembly	17
Vac Motor Assembly	18
17" Brush Deck Assembly	19
17" Brush Deck Assembly BOM	20
20" Brush Deck Assembly	21
20" Brush Deck Assembly BOM	22
E17/20 Brush Hub Assembly	23
E17 Rear Squeegee Assembly	24
E20 Rear Squeegee Assembly	25
Squeegee Mechanism Assembly	26
Wiring Diagrams	27

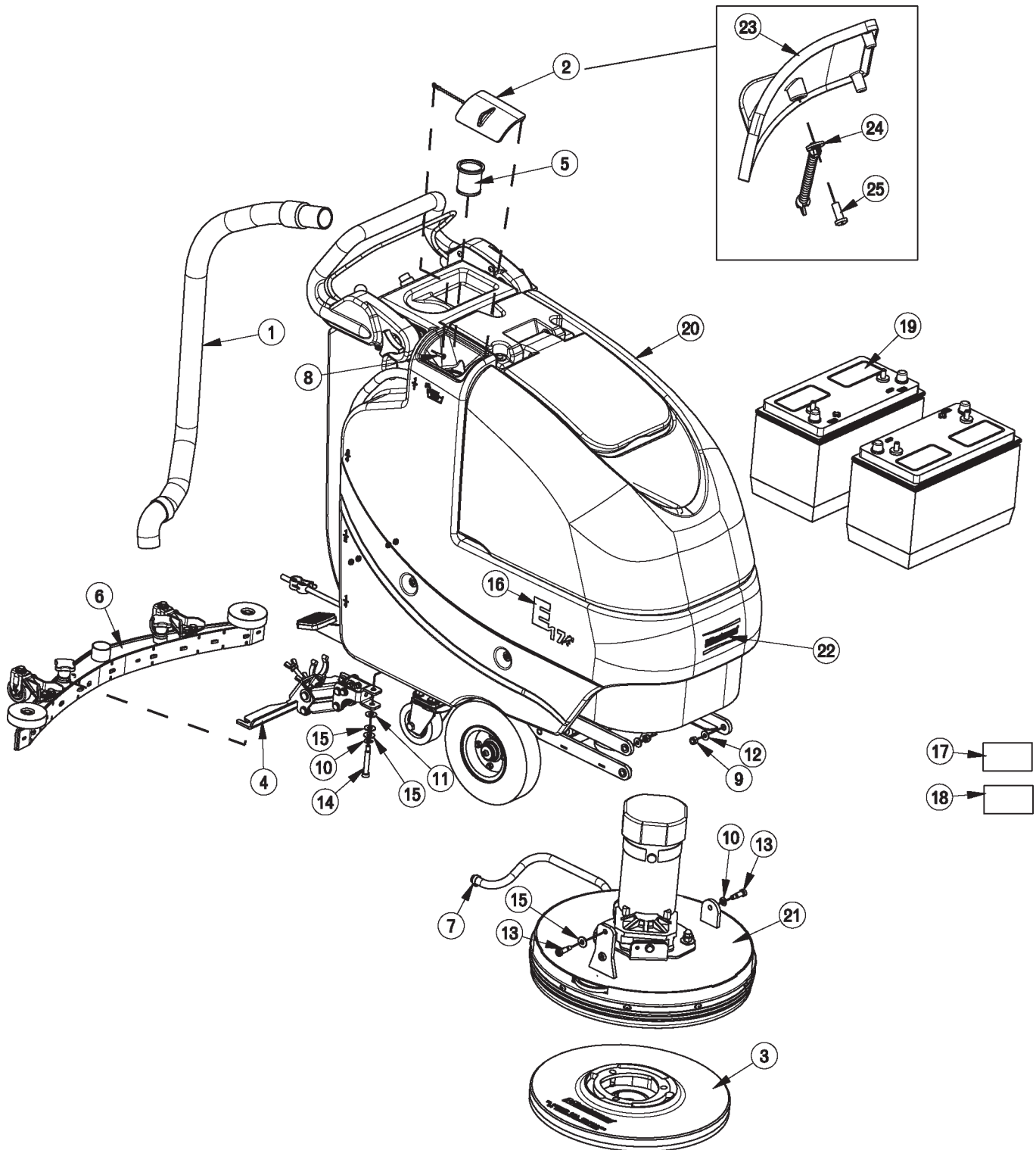

BILL OF MATERIAL			
ITEM	PART NO.	REQ'D	DESCRIPTION
1	172010	1	HOSE, CLEAR VAC W/ 45 CUFF
2	172018	1	SOLUTION TANK LID ASSY
3	172117-2	1	17" PAD DRIVER
3A	172120-2	1	20" PAD DRIVER
4	172150	1	SQUEEGEE LIFT MECH ASSY
5	172159	1	FILTER, FILL PORT, ES1720
6	172220	1	SQUEEGEE ASSY, 30" (760) CURVED
6A	172230	1	SQUEEGEE ASSY, 34" (860) CURVED
7	450076	1	CRIMP CLAMP SS 185R
8	711118	1	SCR-ST-A 10 X .75 SS
9	711374	4	NUT-NYLOC 5/16-18
10	711523	3	WSR-WAVE .37X .68 X .08
11	711569	1	WSR-FLT .390 X .880 X .062 NYL
12	711575	3	WSR-FLT .31x.75x.06ST
13	712081	3	SHOULDER BLT 5/16-18 X 3/8 X0.75
14	712143	1	BLT-SHLD 3/8 X 2.0, 5/16-18
15	712301	3	WSR-FLAT .37 X .87 X .06
16	715917	2	DECAL, E17
16A	715920	2	DECAL, E20
17	740164-1	1	JUMPER CABLE ASSY, RED 4G 12"
18	747649	1	CABLE ASSY, BATTERY E17
19	956140	2	BATTERY, 12V 140AH
19G	956100	2	GEL BATTERY 12V 95AH
20	172001TD-120	1	TRAC DRV BASE ASSY-120V CHARGER
20CE	172001TD-230	1	TRAC DRV BASE ASSY-230V CHARGER
21	172090TD	1	TD BRUSH DECK ASSY 17"
21A	172100TD	1	TD BRUSH DECK ASSY 20"
22	715914W	1	DECAL, MINUTEMAN W/SWOOSHES, WHITE
23	172008	1	SOLUTION TANK LID
24	172123	1	CHAIN, BEADED SS W/ EYELETS
25	712145	1	SCR-PAN HD HI/LO 6-19 X .37SS

OPTIONAL BRUSHES		
ITEM	PART NO.	DESCRIPTION
3.1	172117-1	BRUSH, 17" NYLON
3.2	172117-3	BRUSH, 17" NYLO GRIT 80GR
3.3	172117-4	BRUSH, 17" STRATA GRIT 46GR
3A.1	172120-1	BRUSH, 20" NYLON
3A.2	172120-3	BRUSH, 20" POLY GRIT 80GR
3A.3	172120-4	BRUSH, 20" STRATA GRIT 46GR

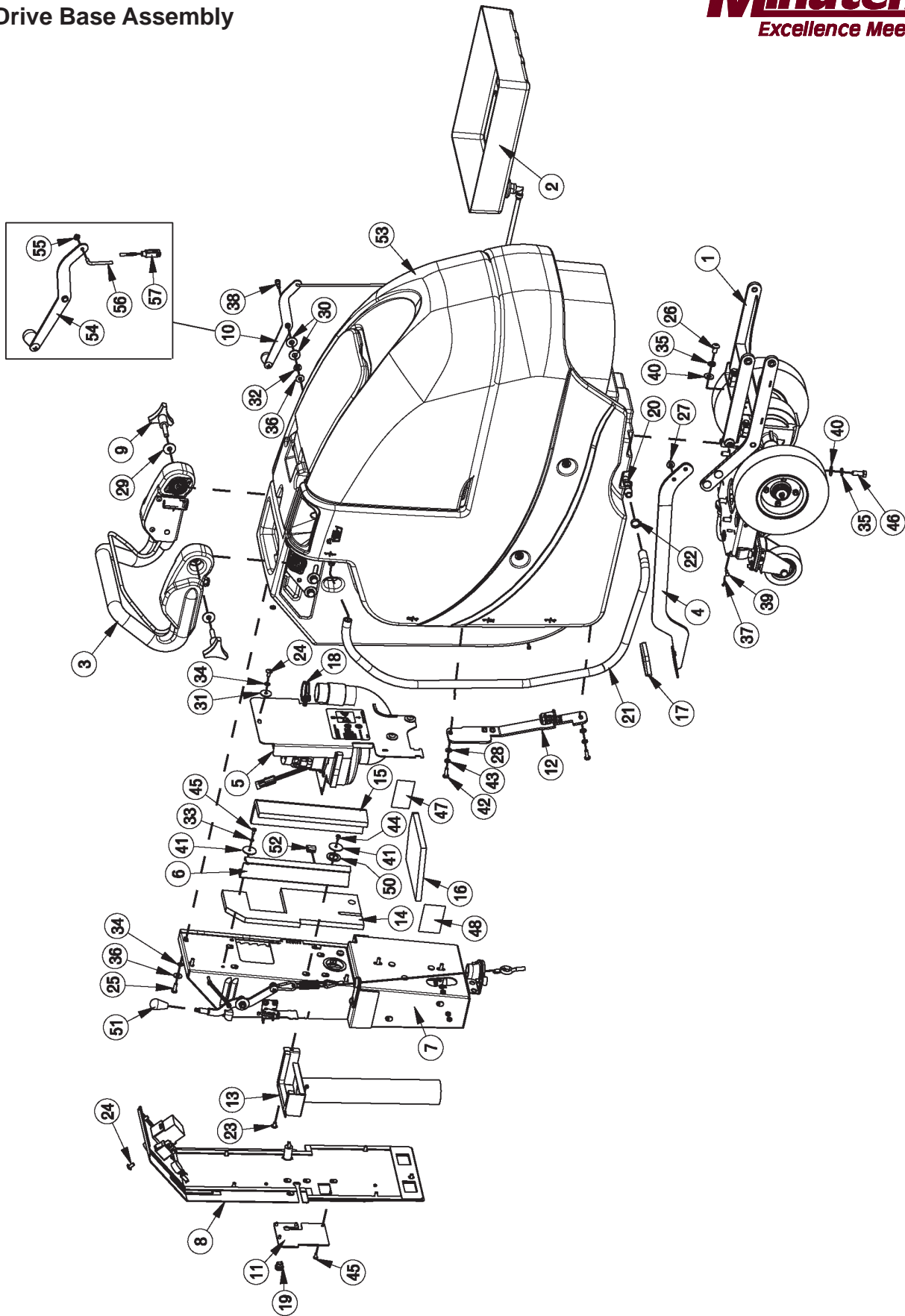

Traction Drive Base Assembly BOM



BILL OF MATERIAL - 172001TD-120/230							
ITEM	PART NO.	REQ'D	DESCRIPTION	ITEM	PART NO.	REQ'D	DESCRIPTION
1	172009	1	TD CHASSIS ASSY, ES1720	30	711508	2	WSR-FLAT .44X 1.0X.08
2	172012	1	BATTERY TRAY ASSY	31	711519	3	WSR- FLAT .25 X 1.01 X .06
3	172015	1	E1720 TD HANDLE ASSY	32	711523	1	WSR-WAVE .37X .68 X .08
4	172032	1	LIFT PEDAL WMT	33	711543	1	WSR-HELICAL #10
5	172050	1	VAC MOTOR ASSY	34	711544	9	WSR-HELICAL 1/4
6	172055	1	BKT, VAC AREA INSIDE COVER	35	711546	6	WSR-HELICAL 3/8
7	172075-120	1	ELEC BOX TD ASSY 120V	36	711575	6	WSR-FLT .31x.75x.06ST
8	172079	1	TD ELEC BOX COVER ASSY	37	711803	1	COTTER PIN-HAIR
9	172085	2	KNOB, 3/8-16 STUD, 3 LOBE	38	712041	1	BLT- SHLDR 1/4-20 X .44 X .37
10	172112	1	SOL CONTROL ASSY	39	712117	1	CLEVIS PIN
11	172129	1	BKT, PWR CORD MOUNT	40	712301	6	WSR-FLAT .37 X .87 X .06
12	172166	1	TD LIFT PEDAL BKT ASSY	41	712312	2	WSR-FLAT .187 X 1.25
13	172179	1	CHARGER INLET ASSEMBLY	42	712562	2	BOLT-HH 1/4-20X3/4 SS
14	172184	1	FOAM COVER, REAR 1	43	712758	2	WSR-HELICAL 1/4 SS
15	172185	1	FOAM COVER, REAR 2	44	712800	1	SCR-MC 10-24 X .25 ST PL
16	172187	1	FOAM COVER, FRONT 2	45	712810	5	SCR-MC 10-24 X .37 ST PL
17	210142	1	PEDAL PAD	46	713042	4	BLT-HH 3/8-16 X 1 #5
18	260203	1	WIRE GRIP HOSE CLAMP	47	715029	1	DECAL-NAME PLATE SERIAL
19	293080	1	STRAIN RELIEF-HEYCO 1207	48	715047	1	DECAL-CLEAR LAMINATE 2X3
20	342440	1	FITTING, TEE 3/4MPT 1/2BARB PP	49	715950	1	LABEL, PATENT NUMBERS
21	430156	1	HOSE, 1/2 X 42 CLEAR	50	717025	1	WSR-FLAT 13/16ID X 1.25 X .08
22	450093	2	CRIMP CLAMP 3/4" STEPLESS	51	760592	1	KNOB, OVAL TAPERED
23	710177	1	SCR-MC 1/4-20 X .37 ST PL	52	809443	1	CLIP-WIRE & CORD
24	710178	10	SCR-MC 1/4-20 X .50 TRUSS STPL	53	172001BASE	1	ES1720 BASE ASSY
25	710380	5	SCR-MC RD HD 1/4-20 X .75 STL PL	54	172115	1	SOL CNTRL LEVER ASSY
26	710985	2	SCR-SC 3/8-16 X .62 ST PL	55	172122	1	NUT, PUSH-ON WSR CAP, 3/16
27	711379	2	NUT, FLANGED WIZZ 5/16-18	56	172069	1	ROD, SOL. CTRL, ES1720
28	711504	2	WSR-FLAT 1/4 ID SS	57	172062	1	YOKE, 3/16 CLEVIS, 10-32, LONG
29	711507	2	WSR-FLAT .37 X 1.12 X .06				

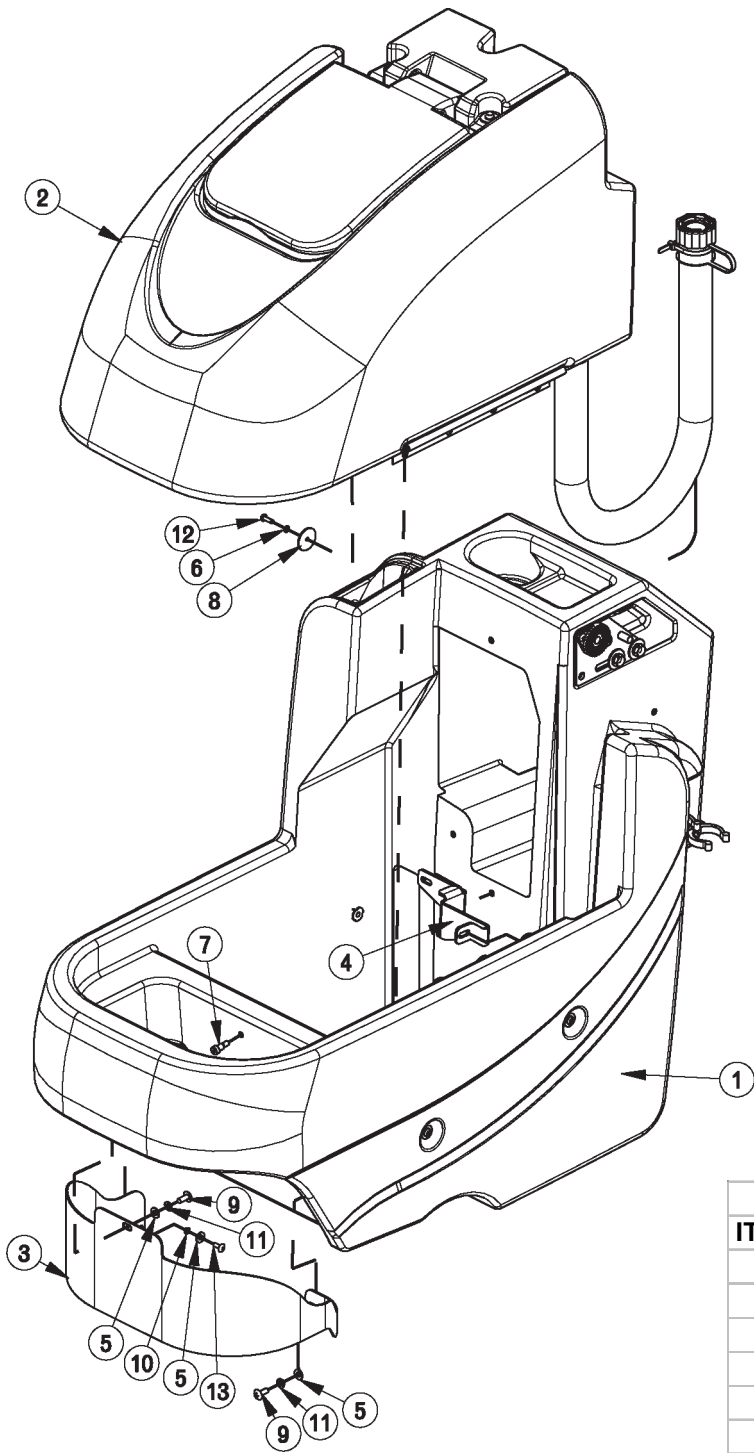

BILL OF MATERIAL - 172001BASE

ITEM	PART NO.	REQ'D	DESCRIPTION
1	172013	1	SOL TANK ASSY, E1720
2	172014	1	REC TANK ASSY
3	172144	1	PANEL, FRONT 1720
4	172211	1	BKT, HOSE RETAINER
5	711504	3	WSR-FLAT 1/4 ID SS
6	711543	4	WSR-HELICAL #10
7	712041	1	BLT- SHLDR 1/4-20 X .44 X .37
8	712312	4	WSR-FLAT .187 X 1.25
9	712565	2	SCR-MC 1/4-20X.63 SS TR HD
10	712757	1	WSR - HELICAL #10 SS
11	712758	2	WSR-HELICAL 1/4 SS
12	712812	4	SCR-MC 10-24 X .62 PPH ST PL
13	712822	1	SCR-MC TR HD 10-24 X .50 SS

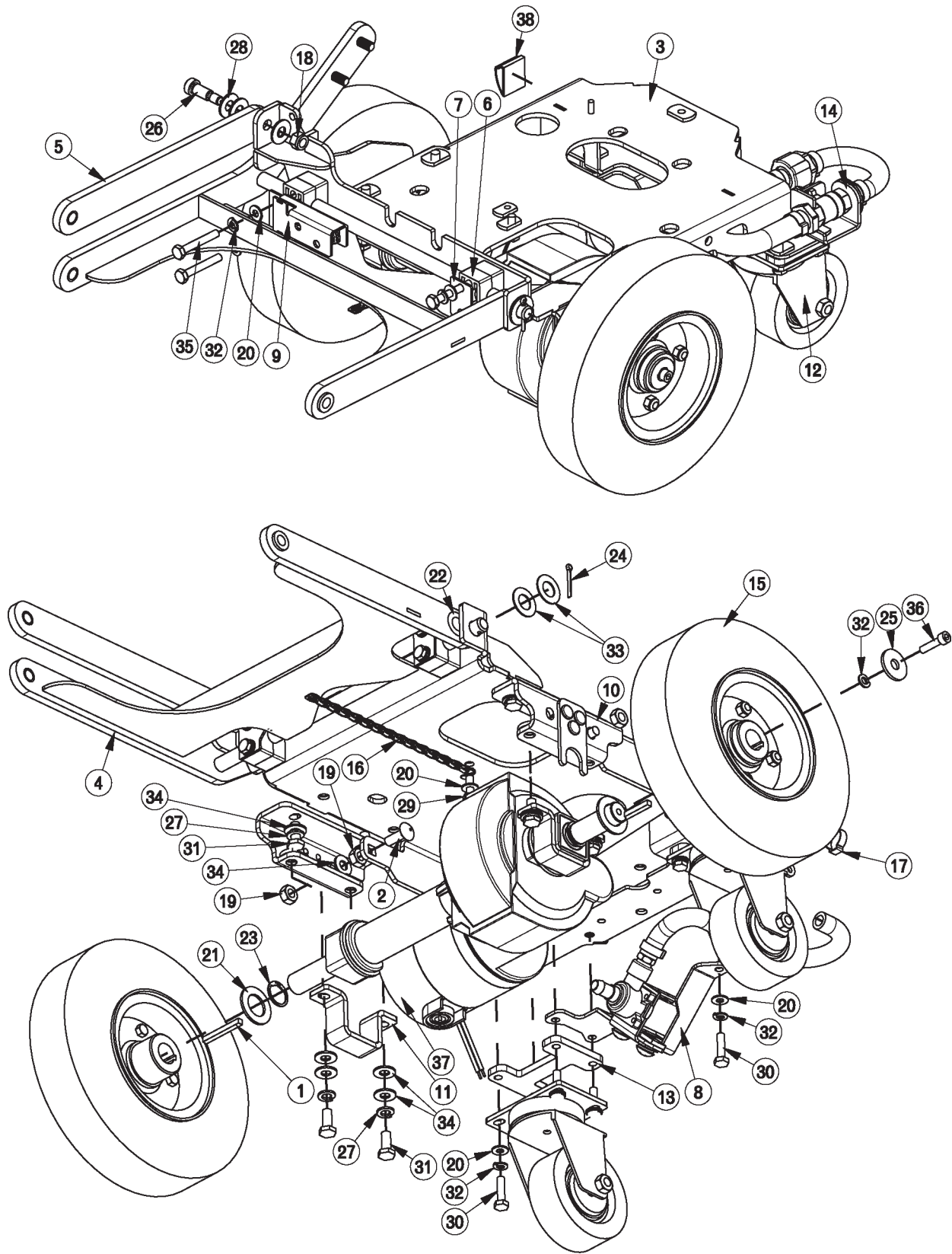

BILL OF MATERIAL - 172009			
ITEM	PART NO.	REQ'D	DESCRIPTION
1	61-65-A	2	KEY, 3/16 X 1-3/4"
2	70-516-16	2	BLT-CAR 5/16-18 X 1.00
3	172020	1	MAIN FRAME WMNT, ES1720
4	172025	1	DECK LIFT ASSY
5	172030	1	BAR, UPPER DECK LIFT W/ BUSH
6	172038	4	BEARING BLOCK
7	172039	1	BEARING BLOCK PLATE
8	172104	1	TD SOLENOID ASSY
9	172110	1	DECK SWITCH ASSY
10	172113	2	BKT, TRANSAXLE MOUNT BASE
11	172114	2	BKT, TRANSAXLE MOUNT
12	172167	2	CASTER, 3-1/2 POLYURETHANE
13	172192	2	PLATE, 1/4" SPACER
14	172264	1	SOLUTION VALVE ASSY
15	200172-2	2	WHEEL, 8.5" FOAM FILL
16	281200	1	DRAG CHAIN ASSY, FRAME
17	450076	1	CRIMP CLAMP SS 185R
18	711374	1	NUT-NYLOC 5/16-18
19	711383	4	NUT-HEX CLR LOC 5/16-18
20	711504	13	WSR-FLAT 1/4 ID SS
21	711512	2	WSR-FLAT .75X1.37X.08
22	711592	2	WSR-FLAT .50 X .9 X .075 NYL
23	711715	2	RETAINING RING EXT .75
24	711809	1	COTTER PIN, 1/8 X 1.0
25	711855	2	WSR-FLT .37X1.12X.10 STL Z HARD
26	712081	1	SHOULDER BLT 5/16-18 X 3/8 X .75
27	712140	8	WSR-HELICAL 5/16 SS
28	712301	3	WSR-FLAT .37 X .87 X .06
29	712562	1	BOLT-HH 1/4-20X3/4 SS
30	712564	8	BOLT-HH 1/4-20X1.00 SS
31	712575	8	BLT-HH 5/16-18 X .75 SS
32	712758	14	WSR-HELICAL 1/4 SS
33	712760	2	WSR-FLAT .56X1.06X.04 SS
34	712772	14	WSR-FLAT .344 x .75 x .06 SS
35	713006	4	BLT-HH 1/4-20 X 1 3/4 #5
36	717026	2	SCR-SC SHCS M6X1.0 X 25 STL Z
37	747606	1	TRANSAXLE, ES1720 24V
38	809444	1	CLIP-CORD

Solenoid Assembly

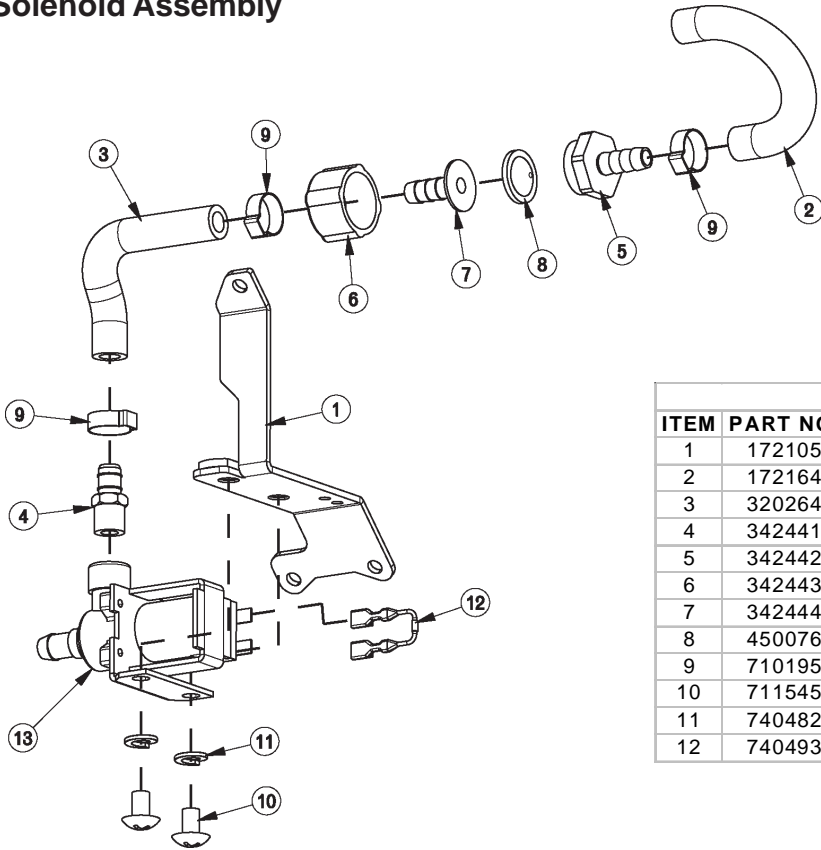

BILL OF MATERIAL - 172104			
ITEM	PART NO.	REQ'D	DESCRIPTION
1	172105	1	BKT, TD SOLENOID MOUNT
2	172164	1	HOSE-NYLO REINF 3/8 X 5.5"
3	320264	1	FITTING BRASS - 3/8 DBL BARB X 1/4MPT
4	342441	1	FITTING, MGHT X 3/8HB PP
5	342442	1	FITTING, FGHT NUT PP
6	342443	1	FITTING 3/8HB INSERT PP
7	342444	1	WSR-FILTER, GARDEN HOSE SIZE
8	450076	3	CRIMP CLAMP SS 185R
9	710195	2	SCR-MC 5/16-18 X .50
10	711545	2	WSR-HELICAL 5/16
11	740482	1	DIODE ASY, 1N4007 W/PIGGY
12	740493	1	WATER VALVE 24VDC

Solution Valve Assembly

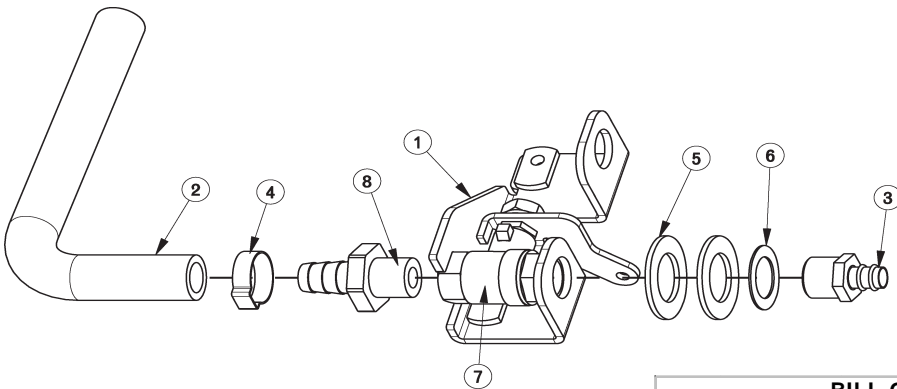

BILL OF MATERIAL - 172064			
ITEM	PART NO.	REQ'D	DESCRIPTION
1	172063	1	BKT, SOL VALVE MOUNT
2	172158	1	HOSE, 1/2"ID X 7.5" NYLOBRAID
3	320265	1	FITTING DUBL 3/8HBx3/8MPT
4	383347	1	CRIMP CLAMP 1/2 HOSE SS 185R
5	711512	2	WSR-FLAT .75X1.37X.08
6	711513	1	WSR-FLAT .69 X 1.06 X .03 SS
7	809415	1	VALVE, 3/8 FPT, 45 OPEN/CLOSE
8	827008	1	FITTING, 3/8 MPT 1/2 HOSE

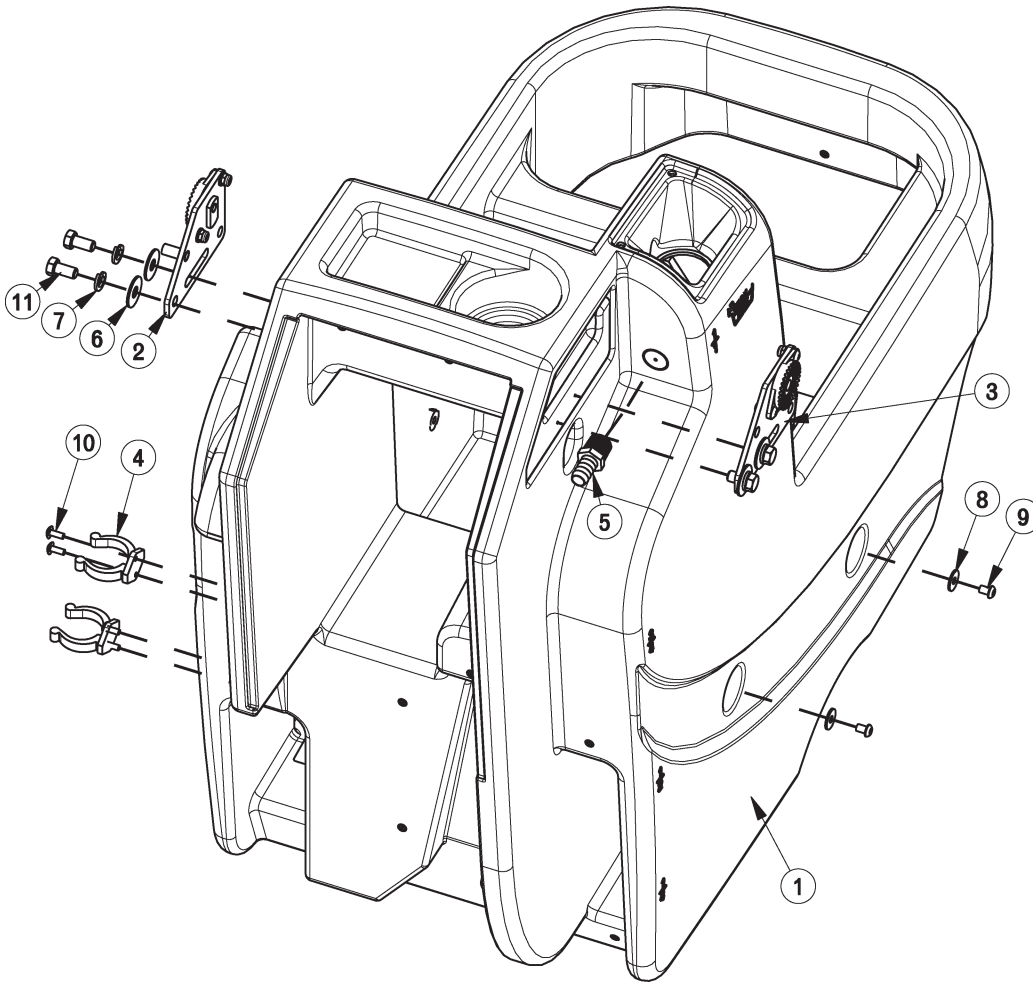

BILL OF MATERIAL - 172013

ITEM	PART NO.	REQ'D	DESCRIPTION
1	172003	1	SOLUTION TANK, ES1720
2	172080	1	HANDLE MOUNT ASSY, LEFT
3	172082	1	HANDLE MOUNT ASSY, RIGHT
4	260579	2	TOOL CLIP, 1.5" HOSE
5	342438	1	FITTING, 1/2 MPT 1/2 HB BRASS
6	711507	4	WSR-FLAT .37 X 1.12 X .06
7	711546	4	WSR-HELICAL 3/8
8	711550	4	WSR NYLON .25 ID X .75 OD
9	712146	4	SCR-SC BHCS 1/4-20 X .37 SS
10	712822	4	SCR-MC TR HD 10-24 X .50 SS
11	713041	4	BLT-HH 3/8-16 X 3/4 #5

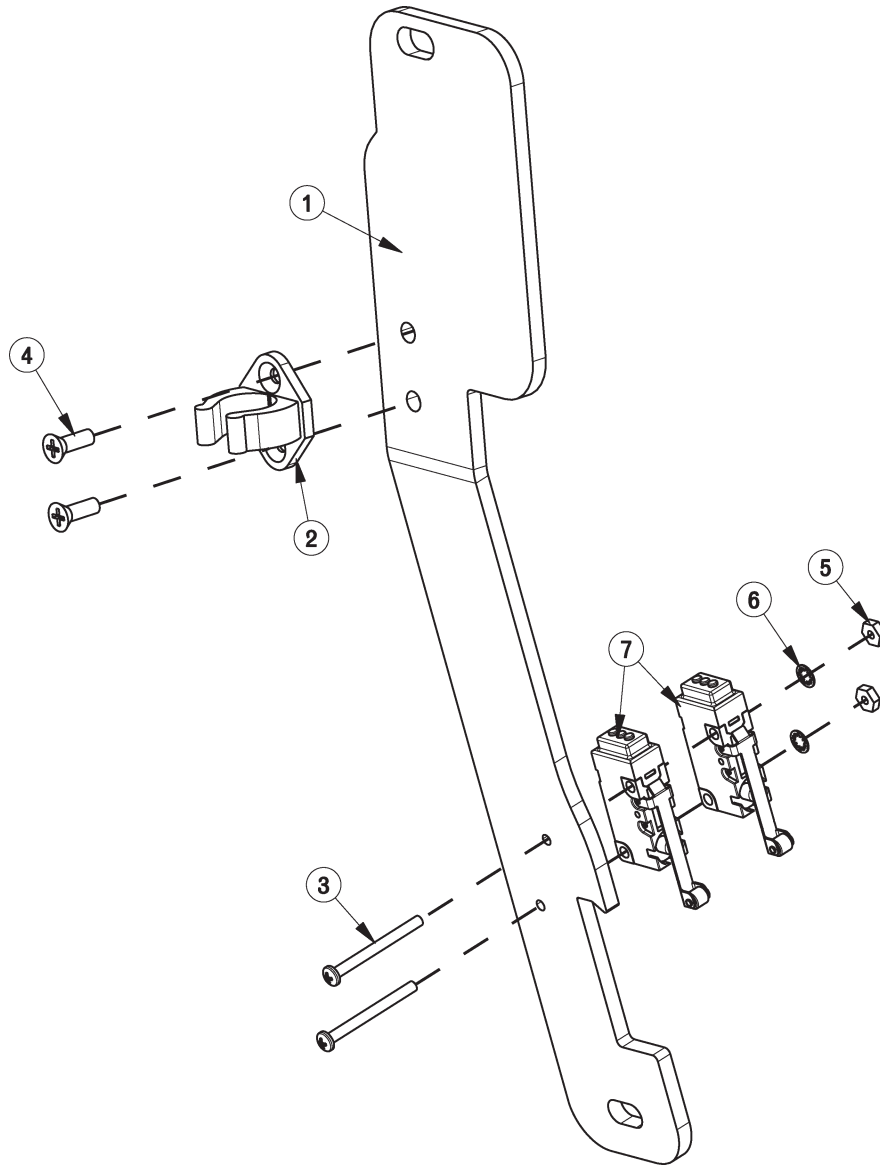

BILL OF MATERIAL - 172166			
ITEM	PART NO.	REQ'D	DESCRIPTION
1	172036	1	BKT, PEDAL STOP
2	172065	1	CLIP, FOR 1/2" ID HOSE
3	710495	2	SCR-MC 4-40 X 1.25 STL Z
4	710530	2	SCR-MC FL HD 8-32 X .50 BRS
5	711428	2	NUT-HEX 4-40
6	712326	2	WSR-INT LOCK #4
7	747603-2	2	SWITCH ASY, MICRO ROLLER W/PACK/CONDUIT

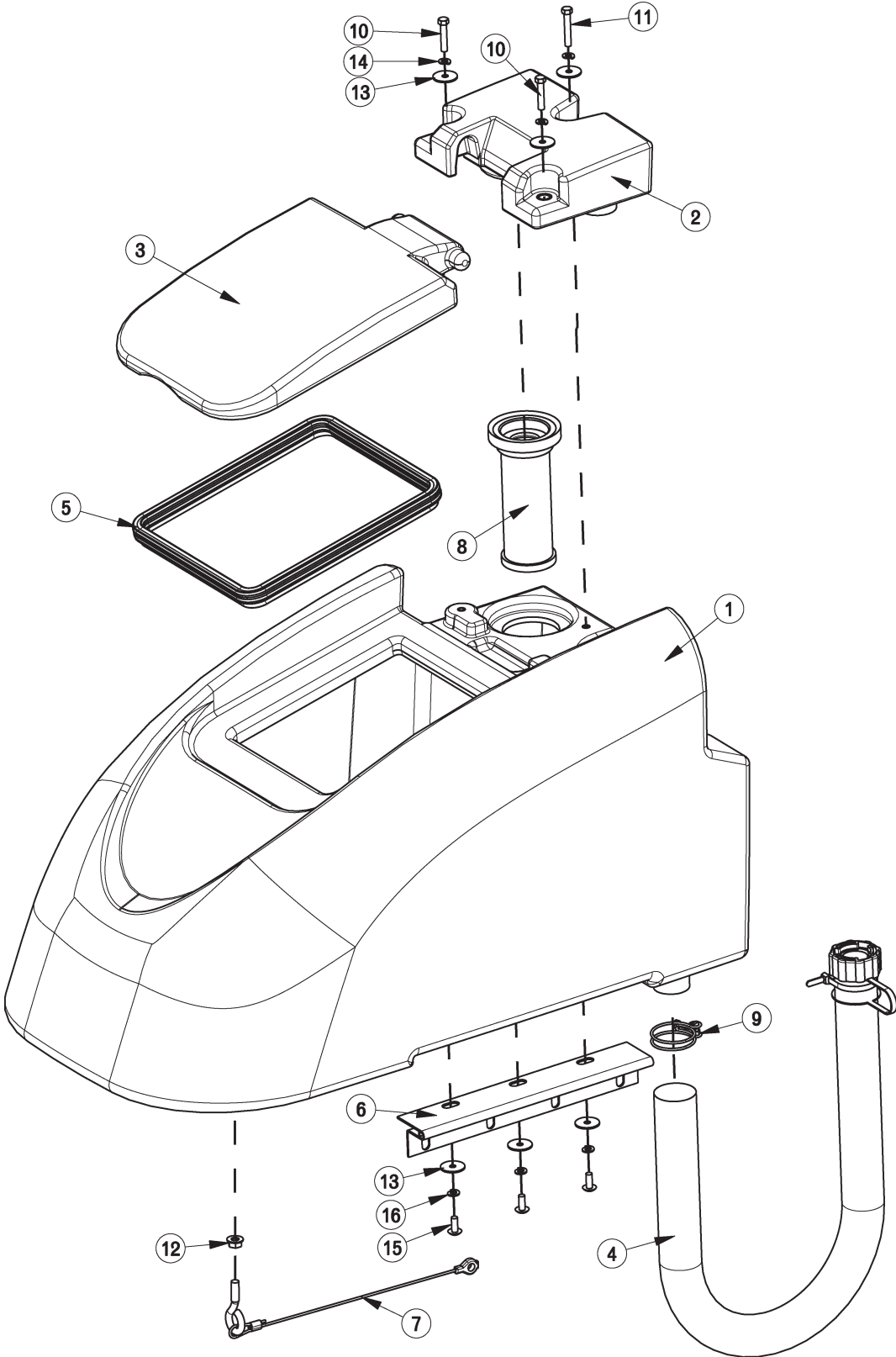

BILL OF MATERIAL - 172014			
ITEM	PART NO.	REQ'D	DESCRIPTION
1	172004	1	ES1720 RECOVERY TANK
2	172005	1	ES1720 VACUUM MANIFOLD
3	172007	1	ES1720 LID
4	172011	1	HOSE, PINCH-OFF W/ CAP, 36"
5	172017	1	GASKET, LID
6	172049	1	HINGE, RECOVERY TANK
7	172067	1	REC TANK CABLE ASSY 11.625
8	172132	1	SCREENED FLOAT
9	260203	1	WIRE GRIP HOSE CLAMP
10	711210	2	BLT-HH 1/4-20 X 1.25 STPL
11	711212	1	BLT-HH 1/4-20 X 1.50 STPL
12	711379	1	NUT, FLANGED WIZZ 5/16-18
13	711519	6	WSR- FLAT .25 X 1.01 X .06
14	711544	3	WSR-HELICAL 1/4
15	712565	3	SCR-MC 1/4-20X.63 SS TR HD
16	712758	3	WSR-HELICAL 1/4 SS

Handle Assembly

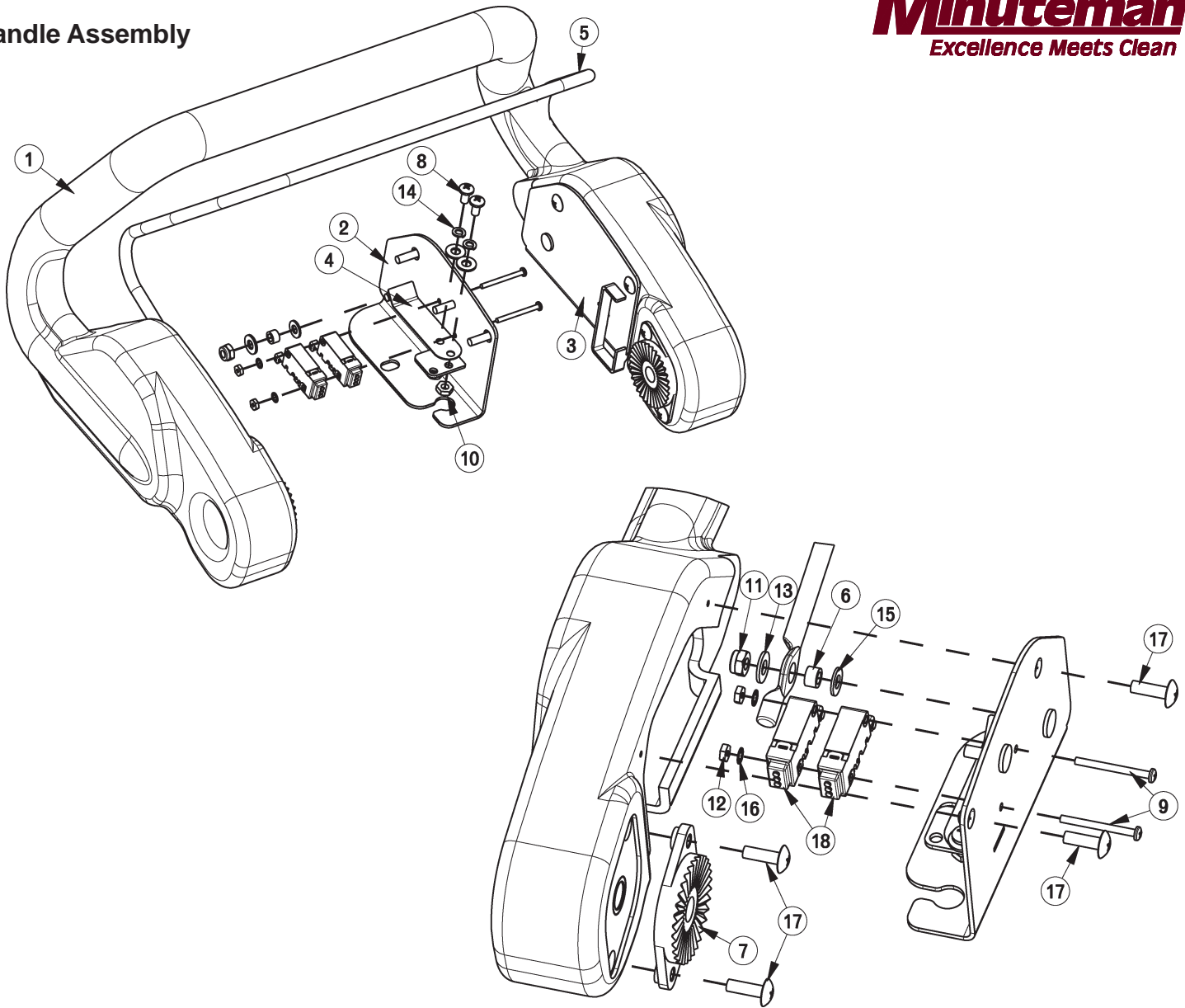

BILL OF MATERIAL - 172015

ITEM	PART NO.	REQ'D	DESCRIPTION	ITEM	PART NO.	REQ'D	DESCRIPTION
1	172006	1	ES1720 HANDLE	11	711350	2	NUT-NYLOC 10-32
2	172053	1	BAIL PLATE WMT RH	12	711428	2	NUT-HEX 4-40
3	172054	1	BAIL PLATE WMT LH	13	711503	6	WSR, FLAT#10
4	172057	2	ES1720 LEAF SPRING	14	711543	4	WSR-HELICAL #10
5	172059	1	ES1720 BAIL, HANDLE	15	712320	2	WSR-NYLON .22 X .45 X .04
6	172074	2	SPACER, 5/16OD X 17GA, ALUM	16	712326	2	WSR-INT LOCK #4
7	270143	2	HANDLE PIVOT JAW	17	712830	10	SCR-MC 10-24 X .62 STLZ TR HD
8	710353	4	SCR-MC RD HD 10-32 X .37 STL	18	747603-1	2	SWITCH ASY, MICRO ROLLER W/PACK/CONDUIT
9	710495	2	SCR-MC 4-40 X 1.25 STL Z	19	747632-1	1	CABLE ASY, 5 COND 18G CONSOLE
10	711310	4	NUT, HEX 10-32 ST PL				

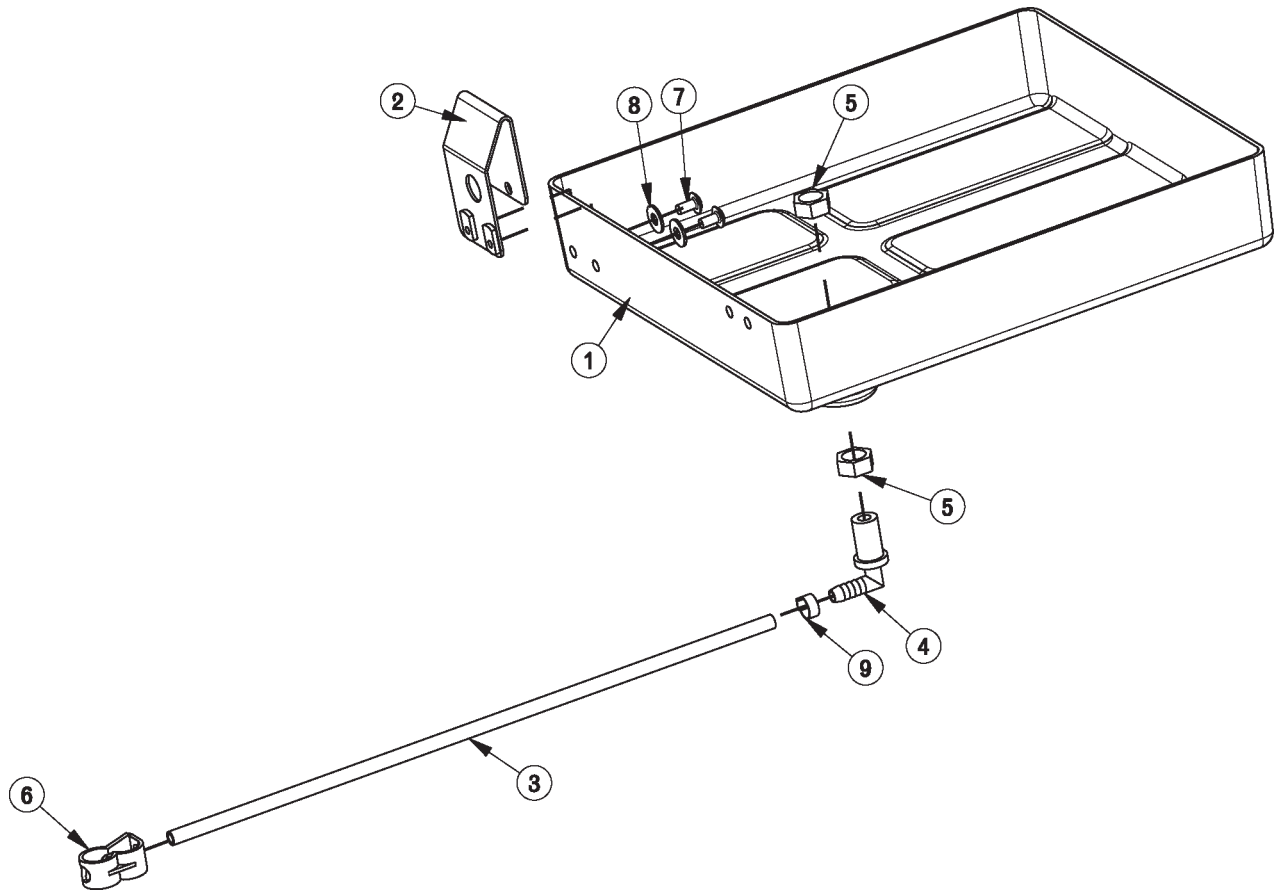

BILL OF MATERIAL - 172012			
ITEM	PART NO.	REQ'D	DESCRIPTION
1	172116	1	ES1720 BATTERY BOX
2	172213	1	BKT, SPACER FOR BATTERIES
3	260224	1	18" HOSE
4	320271	1	NOZZLE BODY-ELBOW
5	320272	2	NOZZLE BODY LOCKNUT
6	320273	1	HOSE SHUT-OFF CLAMP
7	710178	2	SCR-MC 1/4-20 X .50 TRUSS STPL
8	711575	2	WSR-FLT .31x.75x.06ST
9	828490	1	CRIMP CLAMP 140R

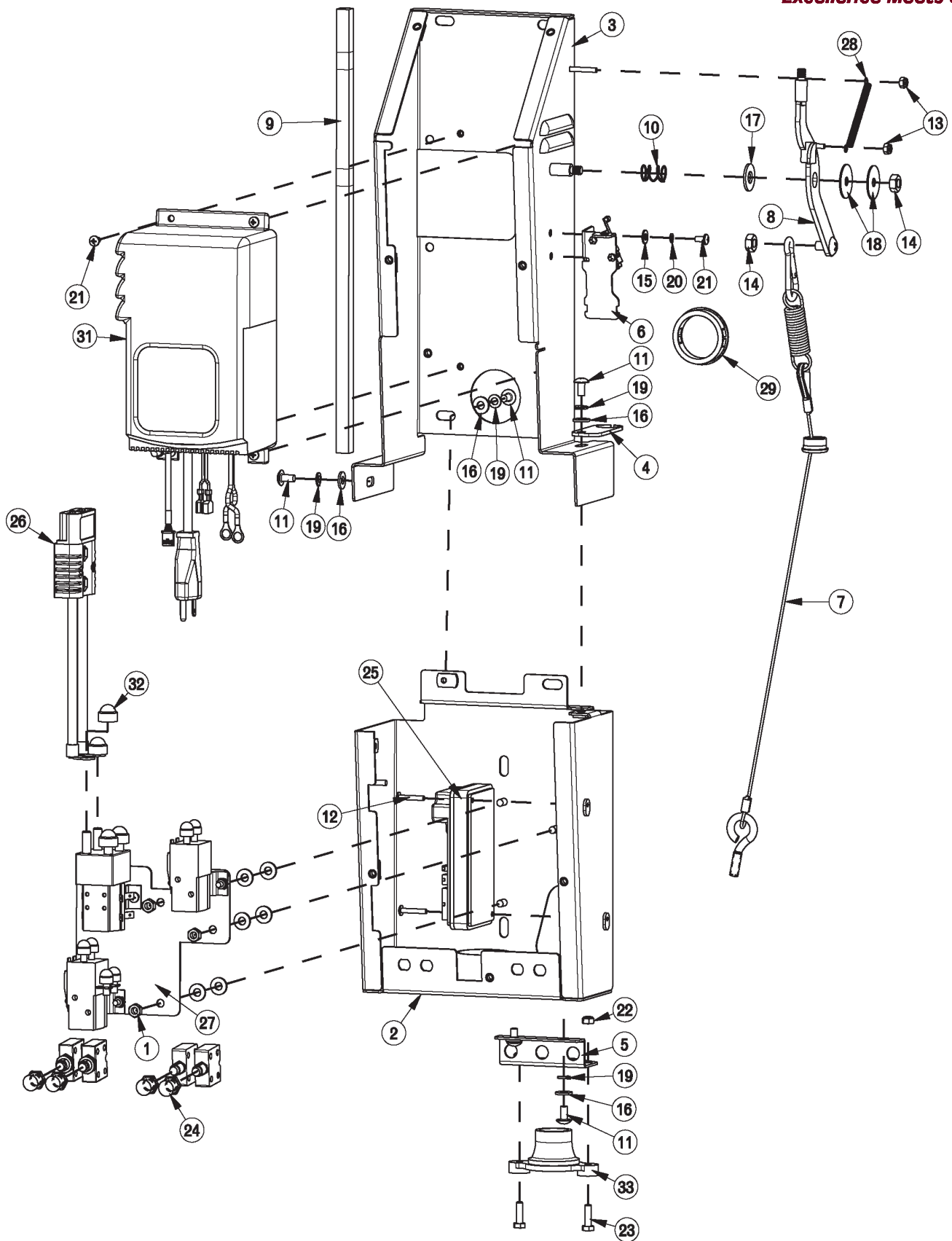

BILL OF MATERIAL - 172075-120/230			
ITEM	PART NO.	REQ'D	DESCRIPTION
1	369-416	3	NUT-HEX 1/4-20 NYLOC SERATED
2	172077	1	ELEC BOX-BOT HALF WMT
3	172088	1	ELEC BOX-TOP HALF WMT
4	172107	1	BKT, UPPER BUSHING MOUNT
5	172128	1	BKT, LOWER BUSHING MOUNT
6	172141	1	VAC SWITCH ASSY
7	172149	1	CABLE ASSY, SQUEEGEE LIFT
8	172152	1	VAC LEVER WMT
9	172188	1	FOAM TAPE, 1/2" SQ X 16.5"
10	670093	1	SPRING, COMPRESSION
11	710178	5	SCR-MC 1/4-20 X .50 TRUSS STPL
12	710534	2	SCR-MC TR HD 8-32 X 1.00 SS
13	711372	2	NUT-NYLOC 8-32 STL ZINC
14	711383	2	NUT-HEX CLR LOC 5/16-18
15	711503	2	WSR, FLAT#10
16	711505	11	WSR-FLAT 1/4
17	711508	1	WSR-FLAT .44X 1.0X.08
18	711516	2	WSR- FLAT .31 X 1.25 X .05
19	711544	5	WSR-HELICAL 1/4
20	712757	2	WSR - HELICAL #10 SS
21	712810	6	SCR-MC 10-24 X .37 ST PL
22	717018	2	NUT-NYLOC M6 X 1.0
23	717022	2	BOLT-HH M6X1.0 X 20
24	742748	4	CIRCUIT BREAKER BOOT
25	747608	1	I-DRIVE,24V 70A PM MOTOR CONTROL
26	747637	1	WIRE ASY, MACHINE-BATTERY E1720
27	747670	1	ELEC PANEL ASSY, E1720TD
28	762084	1	SPRING-EXT
29	762400	1	HEYCO BUSHING 2.00"
30	828062	1	CABLE TIE .05 x .14 x 8"
31	957745	1	CHARGER,24VDC 12A ON-BOARD 120VAC
31A	957753	1	CHARGER,24VDC 12A ON-BOARD 230VAC
32	15592033	2	CAP, SAFETY NUT COVER M8
33	90508391	1	BUSHING, CABLE GUIDE, HAKO

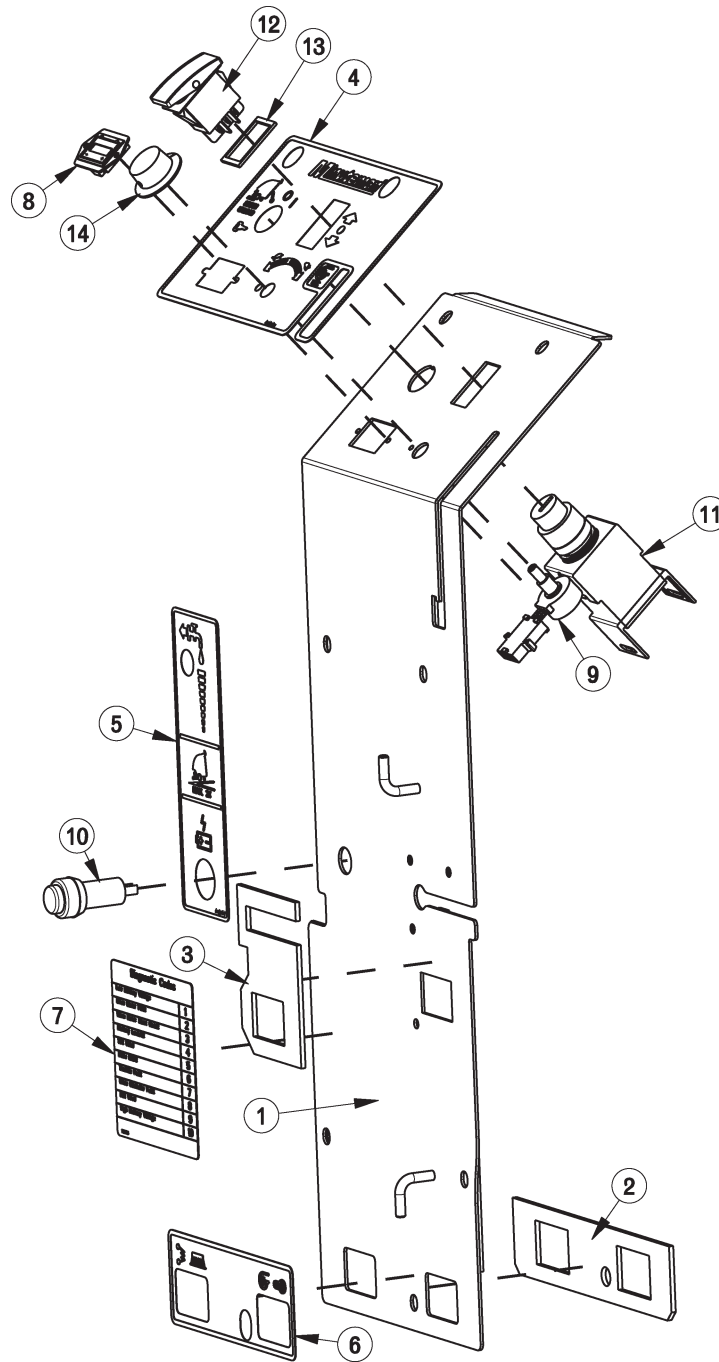

BILL OF MATERIAL - 172079

ITEM	PART NO.	REQ'D	DESCRIPTION			
				8	747011	1 BATTERY GAUGE, TRUCHARGE
1	172182	1	TD COVER WMT		9	747026 1 POTENTIOMETER ASSY SPEED CONTROL
2	172193	1	GASKET, CB OUTLINE		10	747614 1 CHARGE STATUS INDICATOR
3	172194	1	GASKET, CHARGER CORD PLATE		11	747617-2 1 KEYSWITCH ASY, KEYSWITCH + WIR
4	715671	1	DECAL, 1720 TD DASHBOARD		12	748201 1 SWITCH, DPDT ON/OFF/ON
5	715672	1	DECAL, 1720 BD ELEC BOX		13	748209 1 GASKET-FOR 2 POLE ROCKER SWITCHES
6	715674	1	DECAL, TD CIRCUIT BREAKER		14	809874 1 KNOB, SPEED CONTROL
7	715678	1	DECAL. DIAGNOSTIC CODES E1720TD			

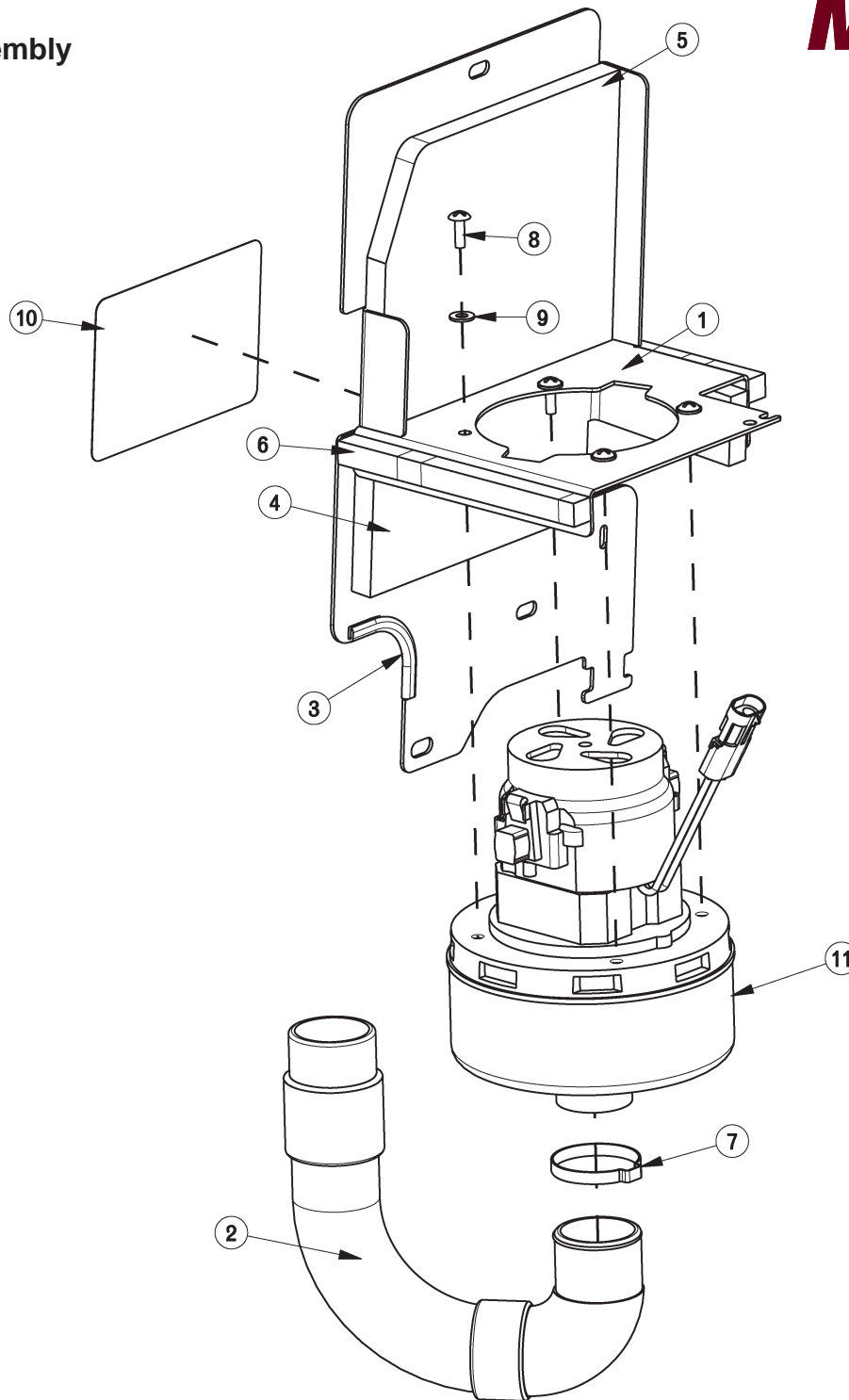

BILL OF MATERIAL - 172050

ITEM	PART NO.	REQ'D	DESCRIPTION	ITEM	PART NO.	REQ'D	DESCRIPTION
1	172045	1	VAC MOUNT WMT, ES1720	7	450095	1	CRIMP CLAMP, 1.75"
2	172048	1	HOSE, STRETCH 13"	8	711160	4	#10 X 5/8 HI-LO
3	172124	1	EDGE TRIM, .063 X 3.0, BLACK	9	711503	4	WSR, FLAT#10
4	172186	1	FOAM COVER, FRONT 1	10	715676	1	DECAL, BATT CABLE ROUTE, E1720
5	172187	1	FOAM COVER, FRONT 2	11	747607-1	1	VAC MOTOR ASY, E1720
6	172188	2	FOAM TAPE, 1/2" SQ X 16.5"				

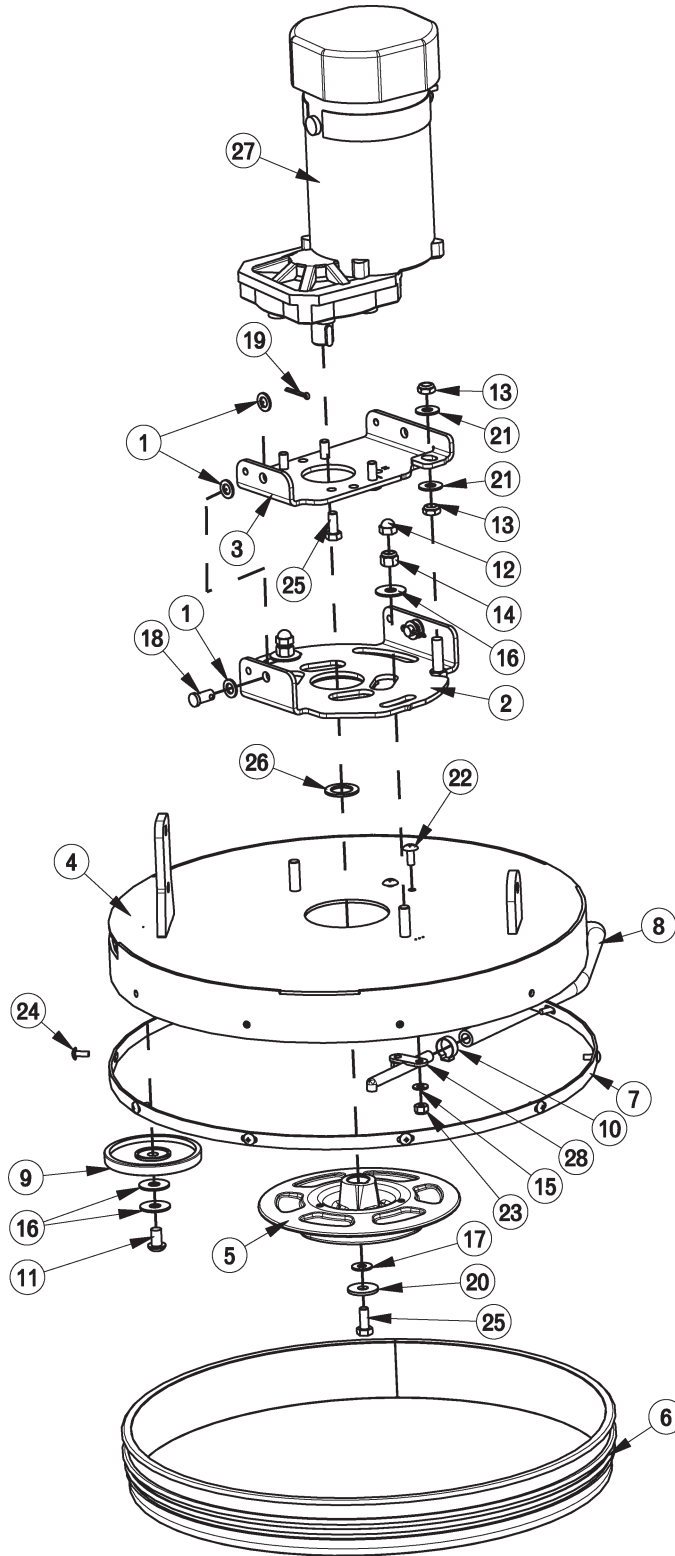

BILL OF MATERIAL - 172090TD			
ITEM	PART NO.	REQ'D	DESCRIPTION
1	81-166-A	6	SPECIAL WASHER
2	172040	1	DECK ANGLE ADJUST WMT
3	172044	1	PLATE, MOTOR MOUNT
4	172091	1	DECK COVER WMT 17"
5	172095	1	E20 BRUSH HUB ASSY
6	172118	1	17" DECK SKIRT
7	172119	1	RETAINER, 17" DECK SKIRT
8	172199	1	HOSE-NYLO REINF 3/8 X 23"
9	210153	1	ROLLER WHEEL
10	450076	1	CLAMP-CRIMP 185R SS
11	710985	1	SCR-SC 3/8-16 X .62 ST PL
12	711354	2	NUT-ACORN 3/8-16 ST NI
13	711375	2	NUT-NYLOC 3/8-16 X 1/2 NUT
14	711380	2	NUT-NYLOC 3/8-16 NUT
15	711504	2	WSR-FLAT 1/4 ID SS
16	711507	4	WSR-FLAT .37 X 1.12 X .06
17	711575	1	WSR-FLT .31x.75x.06ST
18	711679	2	CLEVIS PIN 3/8 X 3/4
19	711809	2	COTTER PIN, 1/8 X 1.0
20	711855	1	WSR-FLT .37X1.12X.10 STL Z HARD
21	712301	2	WSR-FLAT .37 X .87 X .06
22	712565	2	SCR-MC 1/4-20X.63 SS TR HD
23	712667	2	NUT, HEX 1/4-20 NYLOC SS
24	712822	10	SCR-MC TR HD 10-24 X .50 SS
25	717024	5	BOLT-HH M8X1.25 X 20
26	717025	1	WSR-FLAT 13/16ID X 1.25 X .08
27	747600	1	MOTOR, OFFSET PM GEAR, 550W
28	90311663	1	HAKO SOL FEED NOZZLE

20" Brush Deck Assembly

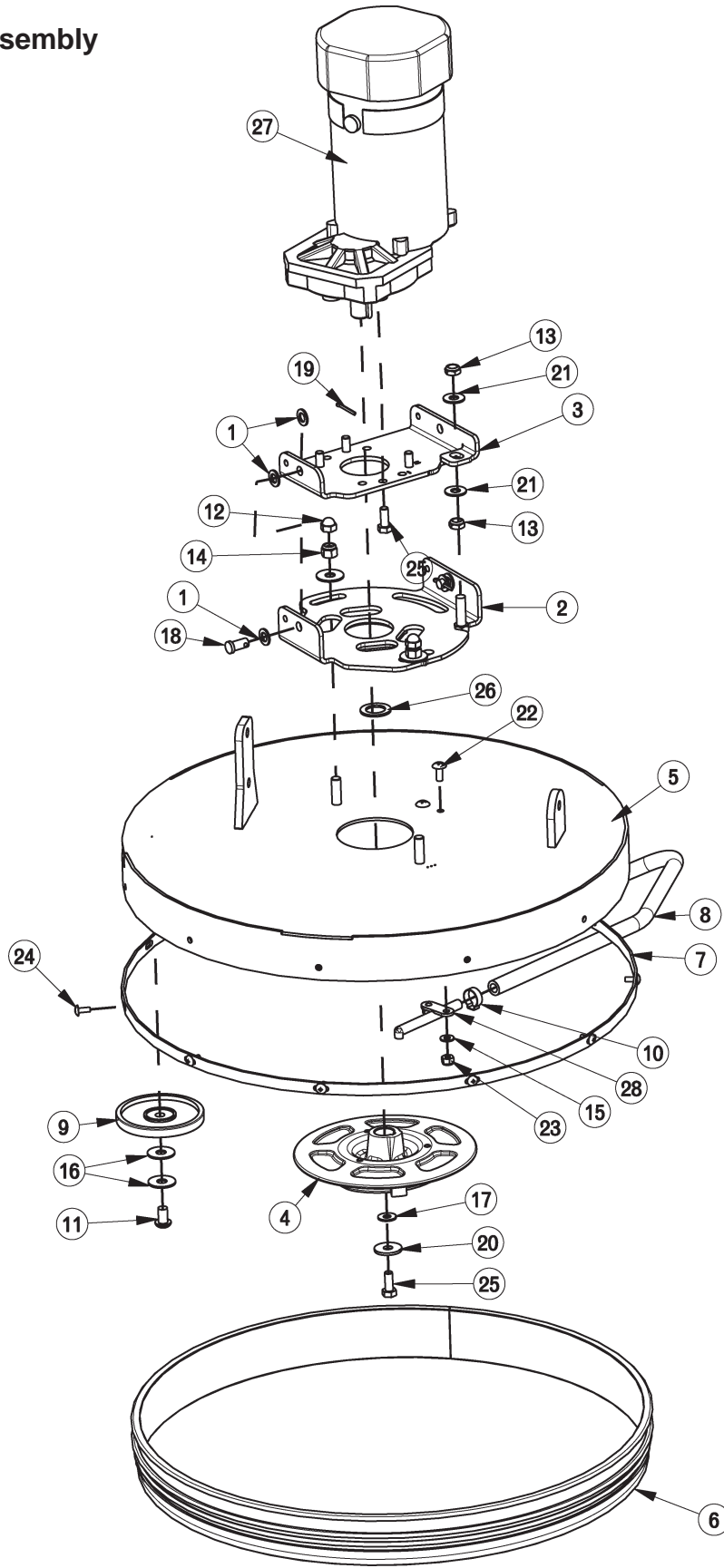

BILL OF MATERIAL - 172100TD			
ITEM	PART NO.	REQ'D	DESCRIPTION
1	81-166-A	6	SPECIAL WASHER
2	172040	1	DECK ANGLE ADJUST WMT
3	172044	1	PLATE, MOTOR MOUNT
4	172095	1	E20 BRUSH HUB ASSY
5	172101	1	DECK COVER WMT 20"
6	172121	1	20" DECK SKIRT
7	172125	1	RETAINER, 20" DECK SKIRT
8	172198	1	HOSE-NYLO REINF 3/8 X 25"
9	210153	1	ROLLER WHEEL
10	450076	1	CRIMP CLAMP SS 185R
11	710985	1	SCR-SC 3/8-16 X .62 ST PL
12	711354	2	NUT-ACORN 3/8-16 ST NI
13	711375	2	NUT-NYLOC 3/8-16 X 1/2 NUT
14	711380	2	NUT-NYLOC 3/8-16 NUT
15	711504	2	WSR-FLAT 1/4 ID SS
16	711507	4	WSR-FLAT .37 X 1.12 X .06
17	711575	1	WSR-FLT .31x.75x..06ST
18	711679	2	CLEVIS PIN 3/8 X 3/4
19	711809	2	COTTER PIN, 1/8 X 1.0
20	711855	1	WSR-FLT .37X1.12X.10 STL Z HARD
21	712301	2	WSR-FLAT .37 X .87 X .06
22	712565	2	SCR-MC 1/4-20X.63 SS TR HD
23	712667	2	NUT, HEX 1/4-20 NYLOC SS
24	712822	11	SCR-MC TR HD 10-24 X .50 SS
25	717024	5	BOLT-HH M8X1.25 X 20
26	717025	1	WSR-FLAT 13/16ID X 1.25 X .08
27	747600	1	MOTOR, OFFSET PM GEAR, 550W
28	90311663	1	HAKO SOL FEED NOZZLE

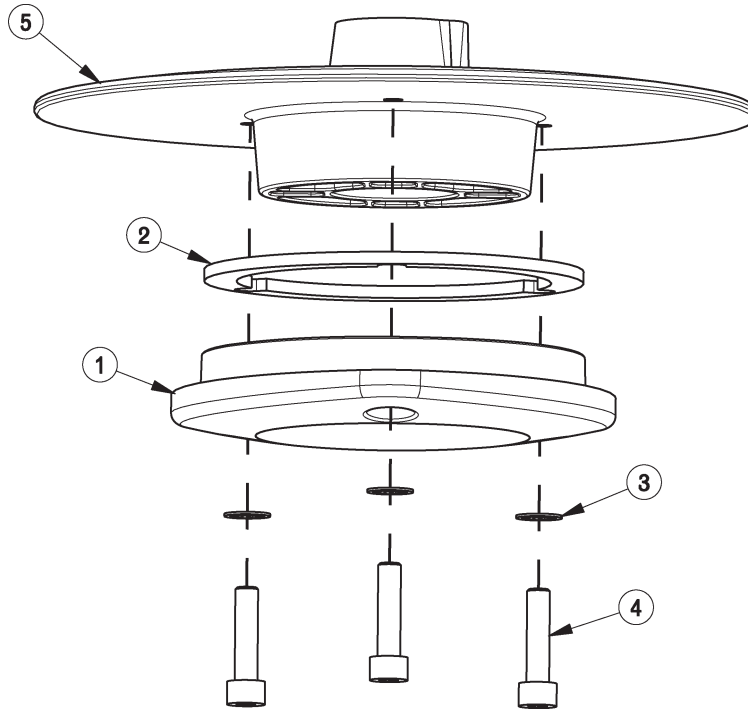

BILL OF MATERIAL - 172095			
ITEM	PART NO.	REQ'D	DESCRIPTION
1	172097	1	ES1720 BRUSH HUB BASE
2	172133	1	BRUSH HUB SPACER
3	711554	3	WSR-INTERNAL LOCK 1/4 ID
4	717026	3	SCR-SC SHCS M6X1.0 X 25 STL Z
5	172096MCH	1	BASE, DRIVE HUB WITH KEYWAY

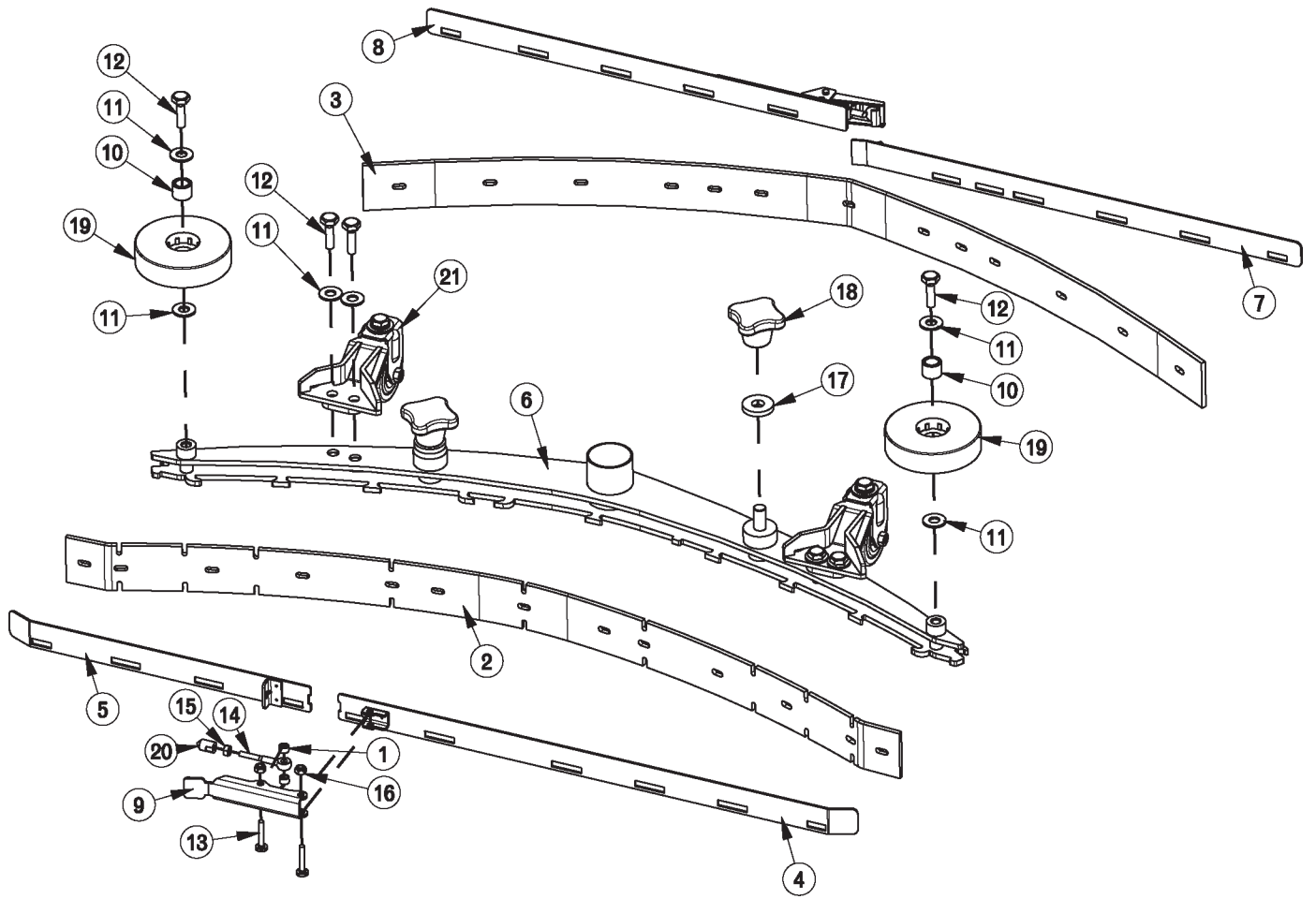

BILL OF MATERIAL - 172220

ITEM	PART NO.	REQ'D	DESCRIPTION	ITEM	PART NO.	REQ'D	DESCRIPTION
1	172074	2	SPACER, 5/16OD X 17GA, ALUM	12	11039567	6	BLT-HH M8 X 25 SS DIN933
2	172218	1	FRONT SQ BLADE, 30" (760)	13	11175494	2	SCR-MC M5 X 25 SS DIN7985
3	172219	1	REAR SQ BLADE, 30" (760)	14	11518313	1	BLT-EYE M5 X 40 SS
4	172223	1	STRAP WMT, FRT LEFT-30" (760)	15	12022430	1	NUT-HEX M5 SS DIN934
5	172224	1	STRAP WMT, FRT RT-30" (760)	16	12040283	2	NUT-HEX M5 NYLOC SS DIN985
6	172225	1	SQUEEGEE WMT, 30" (760)	17	12515094	2	WSR, SQUEEGEE KNOB
7	172226	1	STRAP WMT, REAR LEFT-30" (760)	18	17133026	2	KNOB, M10 STAR HANDLE
8	172227	1	STRAP WMT, REAR RT-30" (760)	19	90336637	2	WHEEL, 3.15OD
9	172234	1	LEVER, 90535758	20	90513631	1	PIN, THD 90513631
10	430322	2	BUSHING .435 X .625 X .50	21	97098842	2	CASTER ASSY
11	712772	8	WSR-FLAT .344 x .75 x .06 SS				

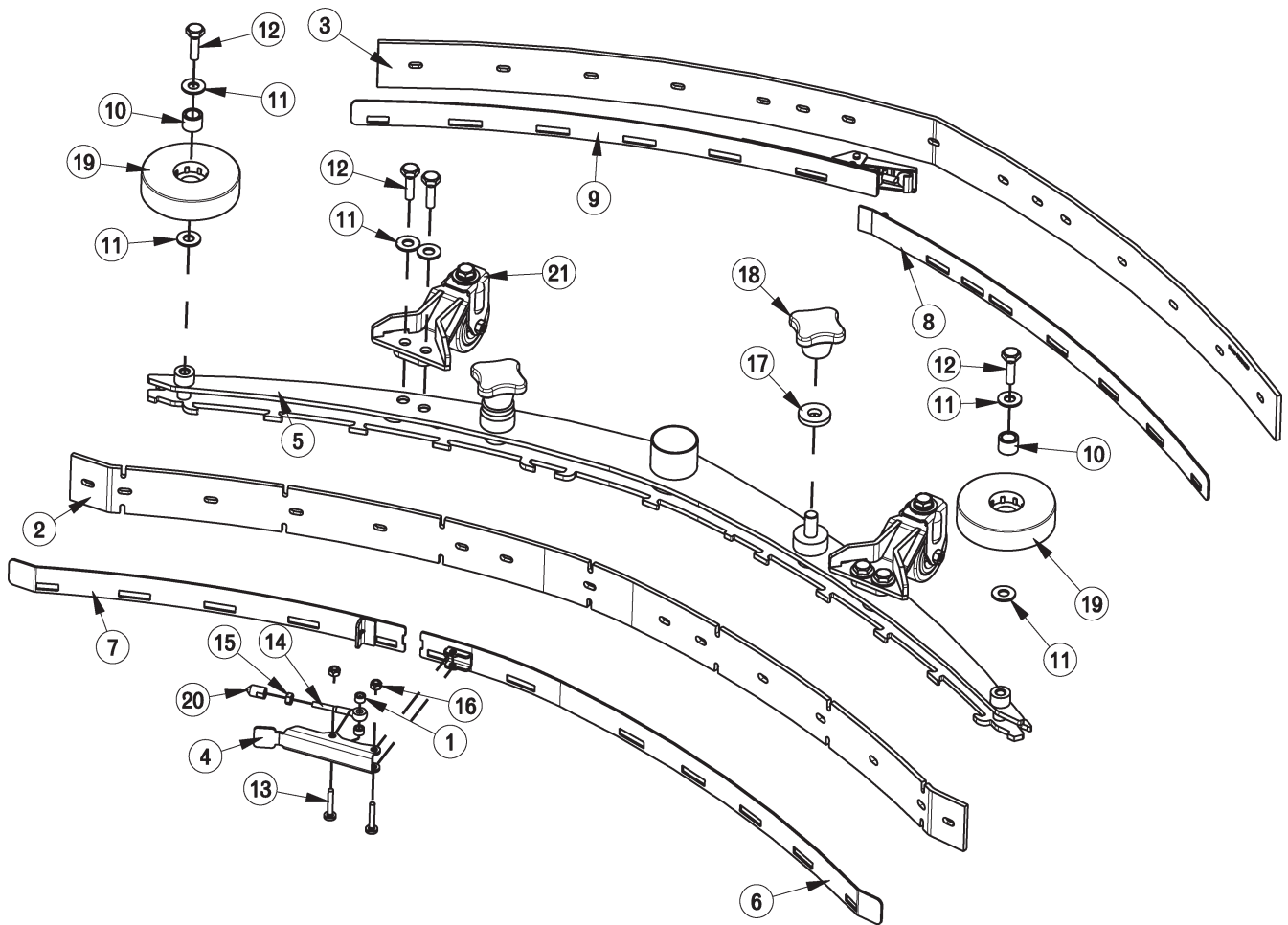

BILL OF MATERIAL - 172230

ITEM	PART NO.	REQ'D	DESCRIPTION	ITEM	PART NO.	REQ'D	DESCRIPTION
1	172074	2	SPACER, 5/16OD X 17GA, ALUM	12	11039567	6	BLT-HH M8 X 25 SS DIN933
2	172162	1	BLADE, FRONT 34" SQUEEGEE	13	11175494	2	SCR-MC M5 X 25 SS DIN7985
3	172163	1	BLADE, REAR 34" SQUEEGEE	14	11518313	1	BLT-EYE M5 X 40 SS
4	172234	1	LEVER, 90535758	15	12022430	1	NUT-HEX M5 SS DIN934
5	172235	1	SQUEEGEE WMT, 860MM	16	12040283	2	NUT-HEX M5 NYLOC SS DIN985
6	172240	1	STRAP WMT, FRONT	17	12515094	2	WSR, SQUEEGEE KNOB
7	172241	1	STRAP WMT, FRONT	18	17133026	2	KNOB, M10 STAR HANDLE
8	172245	1	STRAP WMT, REAR	19	90336637	2	WHEEL, 3.15OD
9	172246	1	STRAP WMT, REAR	20	90513631	1	PIN, THD 90513631
10	430322	2	BUSHING .435 X .625 X .50	21	97098842	2	CASTER ASSY
11	712772	8	WSR-FLAT .344 x .75 x .06 SS				

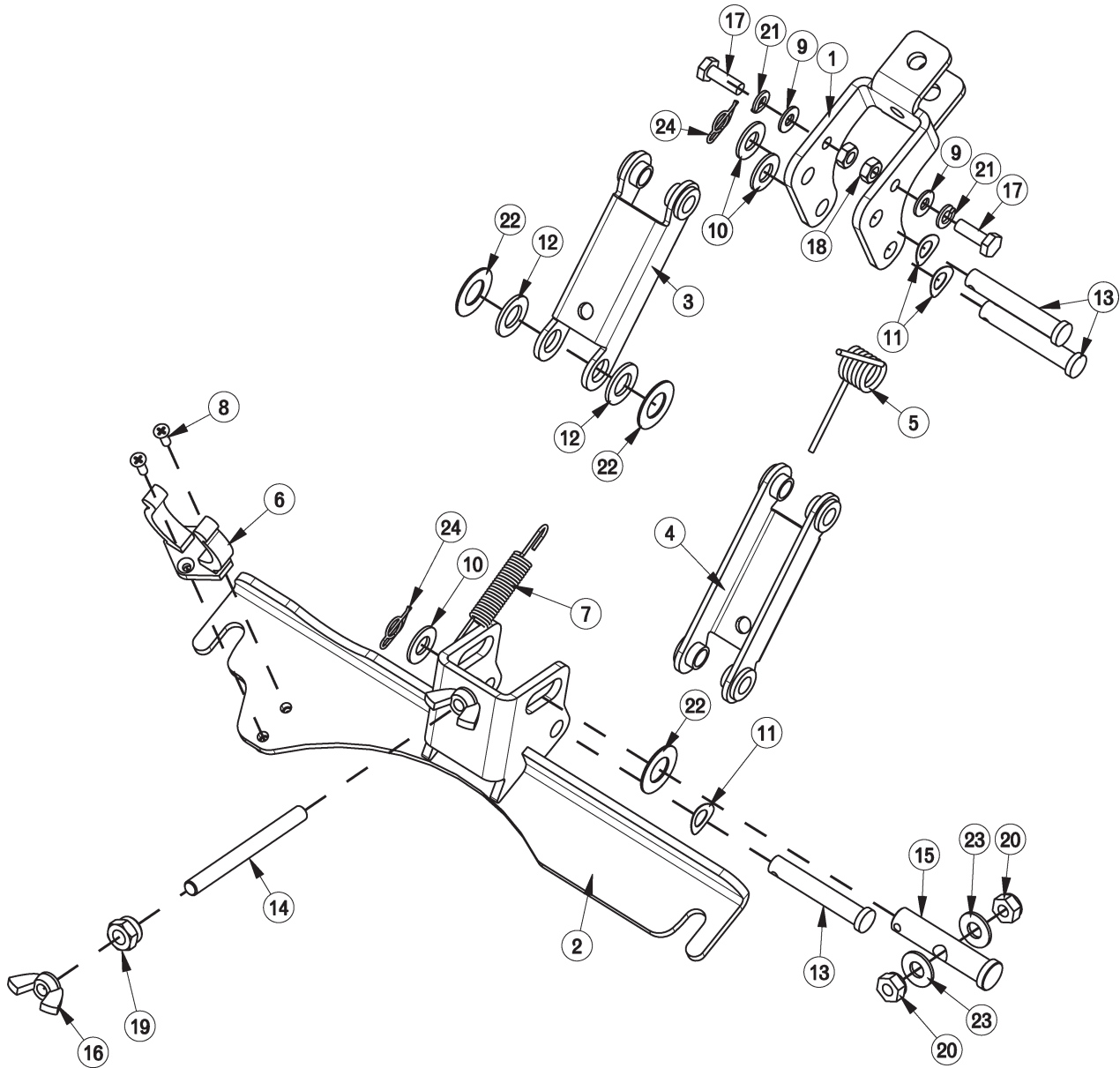

BILL OF MATERIAL - 172150

ITEM	PART NO.	REQ'D	DESCRIPTION	ITEM	PART NO.	REQ'D	DESCRIPTION
1	172134	1	BKT, MAIN SQUEEGEE HINGE	13	711678	3	CLEVIS PIN 3/8 X 2-1/4
2	172155	1	SQUEEGEE MOUNT WMT	14	712147	1	ROD-THD 5/16-18 X 3.5 SS
3	172196	1	SQ TOP LINK W/ BUSHING	15	712148	1	CLEVIS PIN, 1/2 x 2.25 W/ HOLE
4	172197	1	SQ BOT LINK W/ BUSH	16	712157	2	NUT- WING 5/16-18 SS
5	172261	1	TORSION SPRING	17	712562	2	BOLT-HH 1/4-20X3/4 SS
6	260579	1	TOOL CLIP, 1.5" HOSE	18	712665	2	NUT-HEX 1/4-20 SS
7	430051	1	RETURN SPRING-3.00"	19	712680	1	NUT-HEX 5/16-18 SS
8	710530	2	SCR-MC FL HD 8-32 X .50 BRS	20	712683	2	NUT, HEX 5/16-18 NYLOC SS
9	711504	2	WSR-FLAT 1/4 ID SS	21	712758	2	WSR-HELICAL 1/4 SS
10	711515	3	WSR-FLAT .406 X .812 X .0625	22	712760	3	WSR-FLAT .56X1.06X.04 SS
11	711523	3	WSR-WAVE .37X .68 X .08	23	712772	2	WSR-FLAT .344 x .75 x .06 SS
12	711592	2	WSR-FLAT .50 X .9 X .075 NYL	24	3400125	2	PIN-COTTER 3/8 RUE RING

1 Wiring Diagrams

PAGE LAYOUT

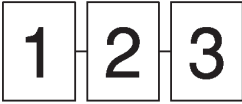

PAGES GO TOGETHER AS SHOWN TO SEE THE ENTIRE SCHEMATIC AS ONE.

715678: DIAGNOSTIC CODE DECAL

- DIAGNOSTIC CODES: BATTERY GAUGE: 747011
 1 BAR : CHARGE BATTERIES
 2 BAR : DRIVE MOTOR CONNECTION
 3 BAR : DRIVE MOTOR SHORT CIRCUIT
 4 BAR : BATTERY LOCKOUT
 5 BAR : NOT USED
 6 BAR : DRIVE INHIBIT
 7 BAR : THROTTLE FAULT
 8 BAR : DRIVE CONTROLLER FAULT
 9 BAR : NOT USED
 10 BAR : EXCESSIVE BATTERY VOLTAGE

ELECTRICAL BOX COVER ASSEMBLY 172079

CONNECTOR #	DESCRIPTION
X1	KEYSWITCH
X2	OPERATOR HANDLE SWITCH
X3	CHARGER STATUS INDICATOR
X4	VACUUM SWITCH
X5	BATTERY CONNECTOR
X6	VACUUM MOTOR
X7	BRUSH MOTOR SWITCH
X8	BRUSH UNLOAD SWITCH
X9	OPTIONAL: SOLENOID SWITCH
X10	OPERATOR HANDLE CABLE
X11	OPERATOR HANDLE CABLE
X12	-
X13	-
X14	-
X15	SOLENOID/HOUR METER CONNECTION
X16	SOLENOID/HOUR METER CONNECTION
X17	OPTIONAL (USED WITH HOUR METER)
X18	OPTIONAL (USED WITH HOUR METER)
X19	BATTERY GAUGE
X20	SPEED POTENTIOMETER
X21	TRANSAXLE SWITCH
X22	OPERATOR HANDLE CABLE
X23	I-DRIVE HARNESS
X24	TRANSAXLE MOTOR

X1: MAIN KEYSWITCH ASSEMBLY: 747617-1

PIN #	COLOR	WHERE TO/FROM
1	RED	X13: BATTERY CHARGER INTERNAL RELAY
2	EMPTY	-
3	RED/VIOLET	BRUSH MOTOR RELAY COIL: 24VDC
4	EMPTY	-
5	EMPTY	-
6	BLACK/BLUE	BRUSH RELAY NORMALLY CLOSED
7	BLACK/BLUE	BRUSH UNLOAD SWITCH P:B
8	RED/VIOLET	X12: MAIN RELAY COIL: 24VDC
9	EMPTY	-
10	EMPTY	-
11	EMPTY	-
12	EMPTY	-
13	EMPTY	-
14	RED/VIOLET	X12: MAIN RELAY COIL: 24VDC

X20: SPEED POTENTIOMETER: 747026

PIN #	COLOR	WHERE TO/FROM
1	BLACK/WHITE	X23: I-DRIVE P:2
2	BLACK/PINK	FORWARD/REVERSE SWITCH 3 TO 1
3	BLACK/ORANGE	X23: I-DRIVE P:8

X22: CONNECTOR TO OPERATOR HANDLE CABLE: 747632-1

PIN #	COLOR	WHERE TO/FROM
1	RED	KEYSWITCH P:1
2	BLACK	CONTROL CB 4.0A
3	RED	MAIN RELAY + (REAR LEFT POST)
4	BLACK	MAIN RELAY - (FRONT LEFT POST)

X22: OPERATOR HANDLE CABLE: 747632-1

PIN #	COLOR	WHERE TO/FROM
1	RED	KEYSWITCH P:1
2	BLACK	CONTROL CB 4.0A
3	RED	MAIN RELAY + (REAR LEFT POST)
4	BLACK	MAIN RELAY - (FRONT LEFT POST)

X23: I-DRIVE HARNESS: 747673

PIN #	COLOR	WHERE TO/FROM
1	BLACK/PINK	X22: P:3
2	BLACK/WHITE	X20: SPEED POT P:1
3	BLACK/GREEN	VACUUM RELAY COIL: 0VDC
4	EMPTY	-
5	RED/WHITE	JUMPER TO P:7 (ON/OFF)
6	BROWN/GREEN	JUMPER TO P:14 (INHIBIT 1)
7	RED/WHITE	JUMPER TO P:5 (24VDC IDRIVE FUSED)
8	BLACK/ORANGE	X20: SPEED POT P:3
9	EMPTY	-
10	RED/YELLOW	X19: BATTERY GAUGE P:2
11	EMPTY	-
12	VIOLET/YELLOW	FORWARD/REVERSE SWITCH 4
13	BLACK/RED	JUMPER TO FOR/REV SWITCH 5
14	BROWN/GREEN	JUMPER TO P:6 (INHIBIT 2)

BATTERY CHARGER: 957745 or 957753

PIN #	COLOR	WHERE TO/FROM
X13	RED	X13: KEYSWITCH P:1
X14	BLACK	X14: CONTROL CB 4.0A
14GA	RED	MAIN RELAY + (REAR LEFT POST)
14GA	BLACK	MAIN RELAY - (FRONT LEFT POST)

OTHER WIRE COLORS

1	RED	BATTERY 24VDC: +
2	BLACK	BATTERY 0VDC: -
3	GREEN/YELLOW	GROUND
4	BLACK/BLUE	BRUSH UNLOAD CIRCUIT
5	RED/BLACK	BRUSH UNLOAD CIRCUIT: MICRO SWITCH
6	RED/VIOLET	24VDC AFTER MAIN KEYSWITCH
7	GREY/RED	OPTIONAL POWER 24VDC: 3A MAX
8	GREY/BLACK	OPTIONAL POWER 0VDC: 3A MAX

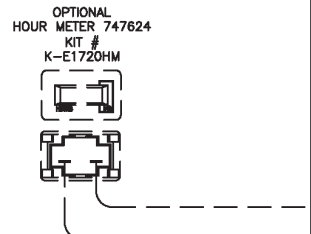
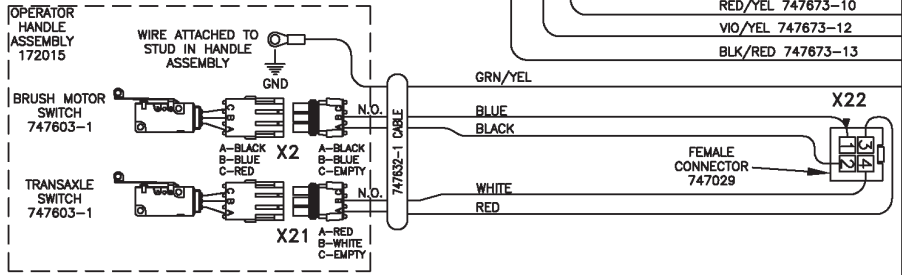
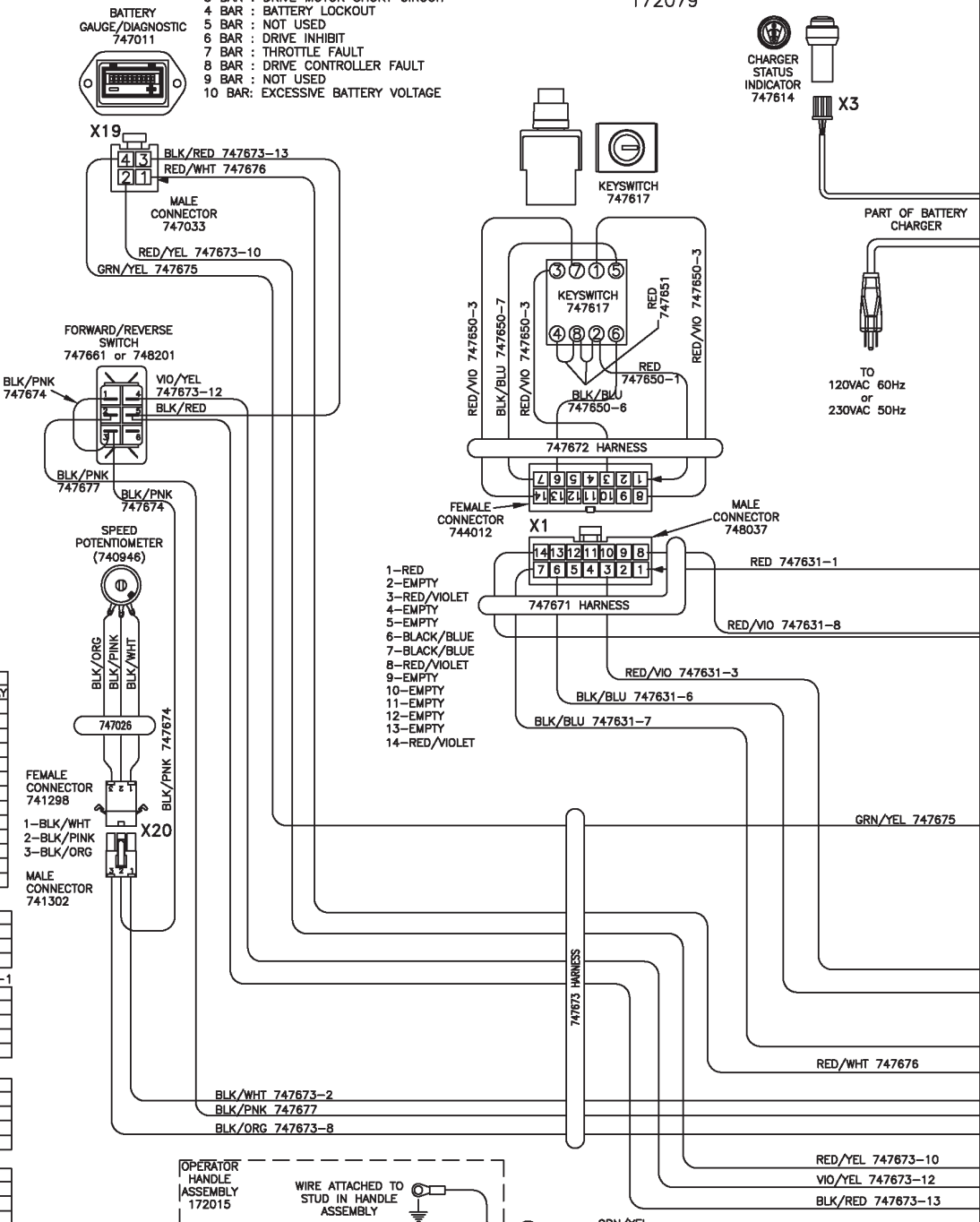

ELECTRICAL
BOX ASSEMBLY
172075-120
172075-230

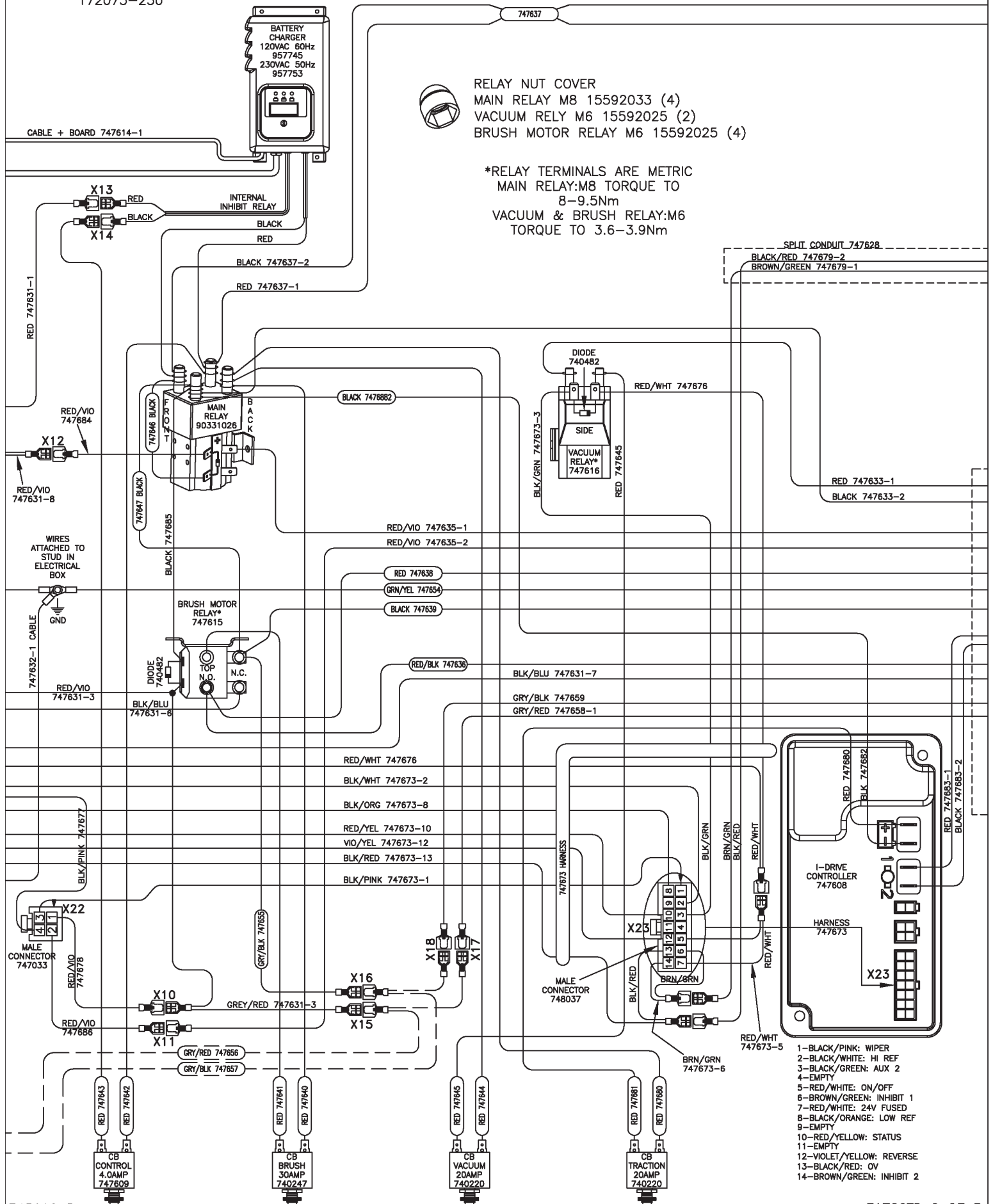

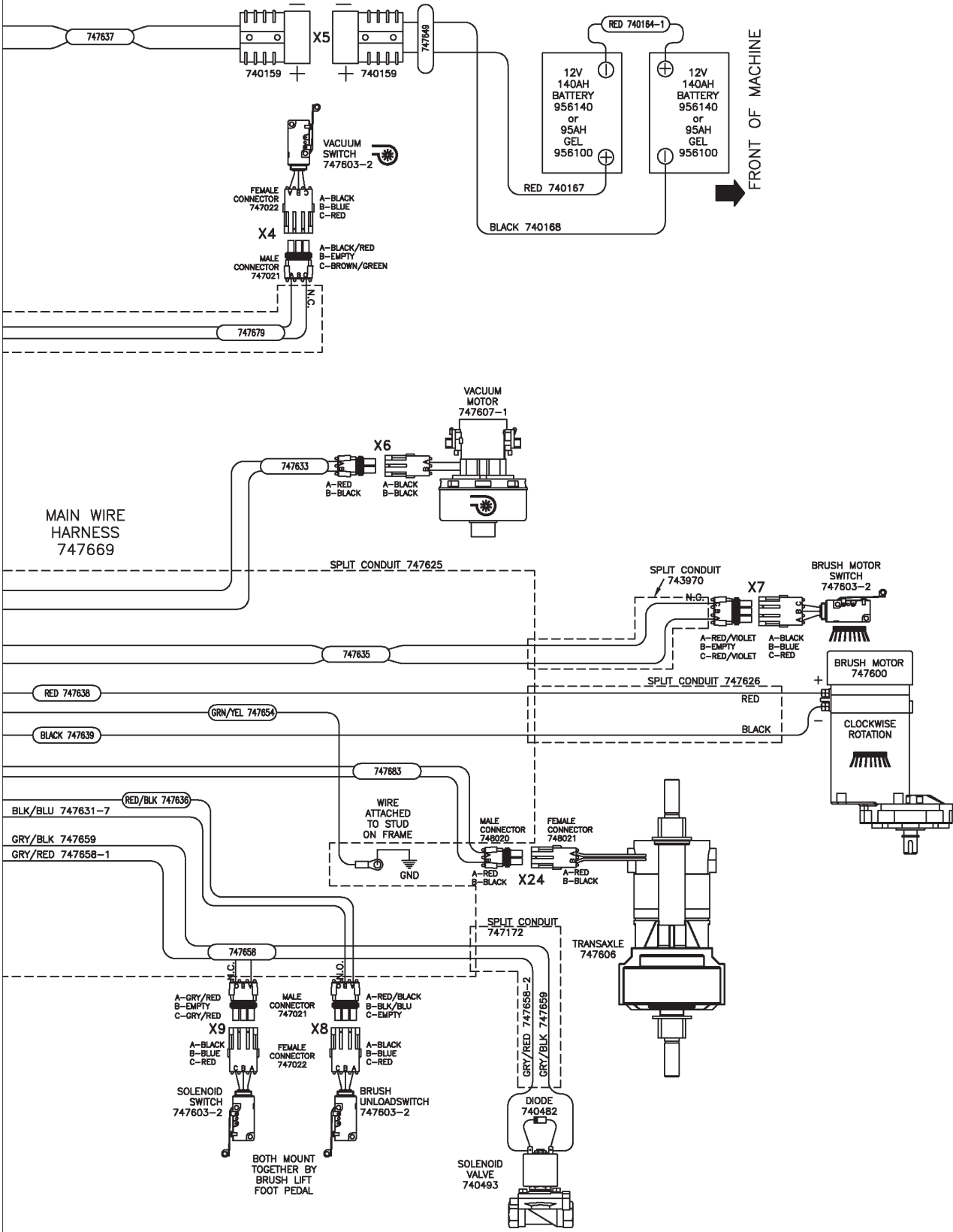

Minuteman International Made Simple Commercial Limited Warranty

Minuteman International, Inc. warrants to the original purchaser/user that the product is free from defects in workmanship and materials under normal use. Minuteman will, at its option, repair or replace without charge, parts that fail under normal use and service when operated and maintained in accordance with the applicable operation and instruction manuals. All warranty claims must be submitted through and approved by factory authorized repair stations.

This warranty does not apply to normal wear, or to items whose life is dependent on their use and care, such as belts, cords, switches, hoses, rubber parts, electrical motor components or adjustments. Parts not manufactured by Minuteman are covered by and subject to the warranties and/or guarantees of their manufacturers. Please contact Minuteman for procedures in warranty claims against these manufacturers.

Special warning to purchaser -- Use of replacement filters and/or prefilters not manufactured by Minuteman or its designated licensees, will void all warranties expressed or implied. A potential health hazard exists without original equipment replacement.

All warranted items become the sole property of Minuteman or its original manufacturer, whichever the case may be.

Minuteman disclaims any implied warranty, including the warranty of merchantability and the warranty of fitness for a particular purpose. Minuteman assumes no responsibility for any special, incidental or consequential damages.

This limited warranty is applicable only in the U.S.A. and Canada, and is extended only to the original user/purchaser of this product. Customers outside the U.S.A. and Canada should contact their local distributor for export warranty policies. Minuteman is not responsible for costs or repairs performed by persons other than those specifically authorized by Minuteman. This warranty does not apply to damage from transportation, alterations by unauthorized persons, misuse or abuse of the equipment, use of non-compatible chemicals, or damage to property, or loss of income due to malfunctions of the product.

If a difficulty develops with this machine, you should contact the dealer from whom it was purchased.

This warranty gives you specific legal rights, and you may have other rights which vary from state to state. Some states do not allow the exclusion or limitation of special, incidental or consequential damages, or limitations on how long an implied warranty lasts, so the above exclusions and limitations may not apply to you.

Cord Electric Group..... Three years parts, two years labor, ninety days travel (Not to exceed two hours)
Exceptions..... Port-A-Scrub, one year parts, six months labor
MPV 13, one year parts
MPV 14 and 18, two years parts, one year labor
RapidAir blower, one year parts, one year labor
Explosion-Proof Vacuum, one year parts, one year labor
Pneumatic Vacuums, three years parts, one year labor
EX 12 and EX12H, one year parts, one year labor

Battery Operated Group..... Three years parts, two years labor, ninety days travel
(Not to exceed two hours)
Exceptions..... Sweepers, one year parts, one year labor, ninety days travel
(Not to exceed two hours)

Internal Combustion Group....One year parts, one year labor, ninety day travel
(Not to exceed two hours)

Replacement Parts.....Ninety days
Batteries.....0-3 months replacement, 4-12 months pro-rate
Polypropylene Plastic Tanks...Ten years, no additional labor