

## MRS - Mercury Recovery System

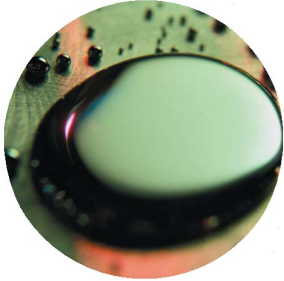

- Allows for safe, affordable clean-up of liquid mercury and mercury contaminated soil and air.
- Mercury Recovery Vacuum System can be tailored to fit almost any particular need. Designed with high-quality stainless steel.
- All units feature a 115v or 220v AC/DC air-cooled motor.
- U.L.P.A. filtration meets or exceeds the IEST-RP-CC0007 specifications

### Key Features

- Extremely portable, highly maneuverable.
- U.L.P.A. filters are 99.999% effective at 0.12 microns.
- Each model contains a large capacity activated carbon filter.
- Unique modular 4-element system that allows user-tailoring to fit almost any need.
- **Tool kit**, which will handle most clean-up jobs, **is included**. P/N: 490011 Dry Only or Wet only.  
P/N: 490010 Dry Only—6 Gallon.

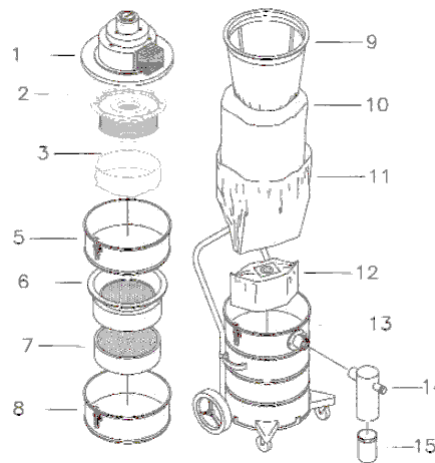

### Filter System - C83015-01

1. Lid Assembly
2. U.L.P.A. Filter-110039
3. Pre Filter-110030PKG
5. Adapter
6. Filter Holder
7. Mercury Vapor Canister-761760
8. Adapter
9. Cloth Bag Assembly-805062
10. Dacron Filter-805005
11. Filter Protector-805038PKG
12. Disp. Paper Bag-760598PKG
13. Tank 15 Gallon
14. Separator
15. Separator Jar-761764



MRS2



MRS4



MRS6

### Specifications

Model	C83015-01	C84015-01	C86006-11
Wet Capacity	Dry Only	15 gal. (Wet Only)	Dry Only
Dry Capacity	.82 cu. ft. (.02m3)	N/A	.62 cu ft(.02m 3/min)
Tank Size	15 gal (57 Ltr)	15 gal (57 Ltr)	6 gal (22 Ltr)
Air Flow	115CFM(3.25m 3/min)	115CFM(3.25m 3/min)	95CFM(2.7m3/min)
Waterlift	110" (2794mm)	110" (2794mm)	88" (2159mm)
Weight	78 lbs(35.5kg)	70 lbs(31.5kg)	24.5 lbs(11kg)
U.L.P.A	YES	N/A	N/A

MINUTEMAN INTERNATIONAL INC.  
14N845 US ROUTE 20  
PINGREE GROVE, IL 60140  
WEB: www.Minutemanintl.com

Phone: 800-323-9420  
Fax: 800-422-6933  
E-mail: customerservice@minutemanintl.com

MINUTEMAN BRAND IS A FULL LINE MANUFACTURER OF SWEEPERS AND SCRUBBERS; AS WELL AS CRITICAL FILTER VACUUMS, INDUSTRIAL AND COMMERCIAL VACUUMS, FLOOR AND CARPET MACHINES, AND LITTER VACUUMS FOR COMMERCIAL AND INSTITUTIONAL FACILITIES. POWERBOSS BRAND IS A FULL LINE MANUFACTURER OF SWEEPERS AND SCRUBBERS FOR INDUSTRIAL FACILITIES.